



# Election Day Guide

**FOR POLL WORKERS**

---

**GENERAL ELECTION**  
**Tuesday, November 5, 2024**

# Where to Turn When You Need Help

RESOURCE	CONTACT INFO	WHEN TO USE
<b>Voter Registration</b> 6:30AM until final vote cast	<b>(610) 891-4659</b> <b>Select option 1</b>	Questions on voter registration, affirmations, Provisional ballots, voter verification, or party registrations.
<b>Voting Machine Warehouse</b> 5:30AM until approx. 10:30PM	<b>(610) 874-8780</b> <b>(484) 229-3385</b>	Questions on voting machines, equipment, or precinct related issues.
<b>Voter Services - Bureau of Elections</b> 6:00AM until approx. 10:00PM	<b>(610) 891-4673 or</b> <b>(610) 891-VOTE (8683)</b>	Questions on ballots and processes. Ask for a solicitor, if necessary, for legal clarification
<b>Poll Worker Hotline</b> 5:30AM to 10:30PM	<b>(484) 460-3750</b>	Urgent questions on paperwork, staffing, Poll Pads and poll worker needs.
	<b>Delcopollworkers</b> <b>@co.delaware.pa.us</b>	Non-urgent questions, comments/observations.
<b>Poll Worker Coordinator</b> 5:30AM to 10:30PM	<b>Call or Text</b> <b>(484) 609-9038</b>	Report staffing vacancies and request assistance.
<b>District Attorney</b> 6:00AM to 10:00PM	<b>(610) 891-4184</b>	Call if suspected crime of voter fraud or voter intimidation, etc. is being committed.

**TIP: Put these numbers in your cell phone under “Election Day,” so they are at your fingertips!**

# Table of Contents

<b>Where to Turn When you Need Help</b> .....	<b>2</b>
<b>INTRODUCTION</b> .....	<b>6</b>
Shared Duties and Responsibilities.....	7
Prohibited Activities .....	7
Poll Watcher and Candidate Guidance .....	8
Poll Watcher Removal.....	8
<b>POLL OPENING &amp; SETUP</b> .....	<b>9</b>
Precinct Overview .....	10
Shared Polling Place Overview .....	10
Task List: Setting up the Precinct .....	11
Item Inventory – Equipment Cage .....	14
Cage Manifest Sheet.....	15
Green Tote & Black Pouch .....	16
White Supply Box & Poll Pad .....	17
Lemon Pay Sheet Instructions .....	18
<b>EQUIPMENT SETUP GUIDE</b> .....	<b>19</b>
Setting up the Ballot Printer .....	20
Setting up the Touch Writer.....	20
Touch Writer Screen Orientation .....	23
Opening the Polls.....	24
Scanner Overview .....	25
Setting up the Ballot Box .....	26
Setting up the Scanner .....	29
Scanner Screen Orientation .....	32
Opening the Polls.....	32
Poll Pad Setup.....	34
Filling out the Return Sheets: Certificate 1.....	38

<b>WORKING WITH VOTERS .....</b>	<b>41</b>
Voter Check-In Overview.....	42
Voters: Allowed and Prohibited Behaviors .....	42
Poll Pad: Voter Check-in Procedure.....	43
Directions to Reprint Poll Pad Ticket.....	46
Instructions: Numbered List of Voters .....	47
Ballot Scanner Procedure .....	48
Scanner Messages and Voter Instructions .....	49
How to Spoil a Ballot.....	50
How to Log an Abandoned Ballot .....	50
Messages & Situations Poll Workers May Encounter.....	51
Address Does Not Match .....	51
Inactive Voter: Affirmation Required .....	51
Unlisted Voter .....	52
ID Required.....	53
Voter is at the Wrong Location.....	54
Voter Requires Assistance .....	55
Return Absentee or Mail-In Ballot or Vote Provisionally .....	56
Returning Ballot or Voting Provisionally Flowchart.....	56
How to Return a Mail-in/Absentee Ballot.....	57
Absentee or Mail-In – Ballot Cast / Not Eligible.....	58
Wrong Voter is Checked In.....	58
Voter May Cast a Provisional Ballot If.....	59
Provisional Ballot Instructions.....	60
Guidance for Challenges .....	61
Voting with the Touch Writer .....	63
Overview: Touch Writer and Verity Access.....	63
About Verity Access .....	63
Installing Headphones and Tactile Switches.....	63
Poll Workers Activate the Ballot.....	64
Marking Ballots with the Touch Writer.....	65
Making Write-in Choices.....	68
Substitutions & Touch Writer Help and Features .....	68

Troubleshooting .....	69
Spoiling Touch Writer Ballots .....	69
<b>CLOSING THE POLLS .....</b>	<b>71</b>
Task List: Closing the Precinct and Polls.....	72
Closing the Polls: Scanner.....	74
Scanner Tally Report Filing Instructions.....	75
Closing the Polls: Touch Writer .....	76
Closing the Polls: vDrive Removal and Return.....	77
Closing the Polls: Packing up the Poll Pad .....	78
Sample Return Sheet.....	79
Filling Out the Return Sheets: Certificate 2 .....	80
Filling Out the Return Sheets: Certificate 3 .....	82
Security Seal Locations .....	84
Return Guide.....	84
Sealed Gray Scanner Ballot Bag w/ vDrive Envelope.....	84
Closing Inventory: Green Tote & White Supply Box.....	85
Provisional Vote – Return Envelope Instructions .....	86
Lemon BOE and Lime Green Poll Pad Envelopes .....	86
Equipment Cage, Aqua MW & Pink Minority Inspector Envelopes .....	87
Drop Off Rules and Information .....	88
<b>Appendix A: Voter Intimidation and Electioneering.....</b>	<b>89</b>
<b>Appendix B: NEW De-Escalation Guidance.....</b>	<b>90</b>
<b>Appendix C: Emergency Information.....</b>	<b>91</b>
<b>Appendix D: Emergency Ballot Box Procedure.....</b>	<b>92</b>
<b>Appendix E: Replacing Machine Tapes .....</b>	<b>93</b>
<b>Appendix F: Voters with Specific Needs.....</b>	<b>94</b>
<b>Appendix G: Poll Pad Issues .....</b>	<b>95</b>
<b>Appendix H: NEW Poll Worker Positions .....</b>	<b>96</b>
<b>Appendix I: Machine Reports .....</b>	<b>97</b>
<b>Election Day – Poll OPENING Checklist.....</b>	<b>99</b>
<b>Election Day – Poll CLOSING Checklist .....</b>	<b>100</b>

**Remember: Whether you are a new or experienced poll worker, always review your guide; there are always changes from election to election!**

# Introduction

Dear Election Board Members,

On behalf of our 400,000-plus voters and the Board of Elections, thank you for your commitment to helping Delaware County citizens exercise the right to vote!

This Election Day Guide is your manual. We strongly encourage reading the guide AND attending an in-person training. In-person training includes hands-on work with the Poll Pad. We also will provide tips in class on how to streamline check-ins to minimize lines.

NOTE: Judges of Election (JOEs) will receive training pay ONLY if they: (1) pass the test, (2) serve successfully AND, (3) have attended an in-person training for this election -or- one of the in-person trainings ahead of the April 2024, Nov. 2023, or May 2023 elections. If you are a JOE and you do not know the last time you attended in-person training, call the Poll Worker Hotline.

The Election Day Guide, and the in-person training, will help you:

- Set up your polling place properly and use the Poll Pads to check in voters,
- Use the Touch Writer to print Provisional Ballots,
- Enforce the rules for poll watchers to keep your precinct a “campaign-free zone,” and,
- Properly close the polls and finish your paperwork.

NEW this election: We limited changes to items that are designed to make your job easier.

- To make way for bigger turnout, we are supplying **more three-fold tabletop voting stations**. Return these tabletop voting stations in the cage. These are NOT disposable items.
- Return your redesigned **Spoiled/Remitted Ballot Envelope** in the cage – along with the Numbered List of Voters Binder, Aqua Machine Warehouse envelope and the box of unused ballots.
- We highlighted **areas on the Provisional Ballot Envelopes where the voter, the JOE and the Minority Inspector must sign**. Be sure to complete all sections of that envelope! The Provisional Voting – Return Envelope has also been redesigned.
- In-person training will include tips on streamlining check-ins.
- All precincts will have a metal color-coded “menu” style sign (beige, gray, gold, green, purple, or pink) on a stand along with color-coded laminated signs. These will be in the cage. These are intended to help you direct the voter from the Poll Pad table to the correct precinct table.

What is the SAME this election? Most everything else. That includes our commitment to smooth drop-offs and issuing paychecks as quickly as possible.

We look forward to working with you, and we welcome your feedback.

Regards,

Jim Allen  
Elections Director

## Shared Duties and Responsibilities

- Participate in in-person or on-line training and pass the poll worker test to understand how to use our equipment and process a voter.
- Arrive at polling location at 6:00AM to set up the precinct.
- Conduct the election lawfully and ensure all voters have privacy while voting and that all voters are treated with courtesy.
- Wear a supplied name tag.
- Close the precinct after all voters in line at 8:00PM have voted.

Elected, court-appointed and emergency appointed Judges of Elections (JOE) and Inspectors must serve the entire Election Day, 6:00AM to approximately 9:00PM. ONLY Clerks and Machine Operators may serve ½ day shifts from 6:00AM to 1:00PM or 1:00PM to close.

**TIP: PREPARE FOR A FULL DAY! Bring everything you need for a very long day. This can include snacks, water, coffee, medications, phone charger, comfortable shoes, an extra layer of clothes, etc.**

## Prohibited Activities

- Poll workers must **NOT** engage in partisan activity or distribute literature.
- Poll workers must **NOT** wear apparel, buttons or ribbons for or against a candidate, party or question on the ballot.
- Poll workers must **NOT** pre-fill any sections of the voter's ballot or tell voters how to vote or answer questions about candidates.
- Poll workers must **NOT** participate in or allow unlawful hand counts of the scanned ballots. Poll workers **MUST** follow chain of custody rules for closing the polls.
- Do not allow anyone who is **NOT** a poll worker (anyone that has not taken the Election Officer's Oath nor signed the Pay Sheet) to sit at the poll worker table. Candidates, greeters, visiting family and friends and poll watchers are **NOT** poll workers.
- Poll watchers, elected officials, greeters, and candidates **CANNOT** approach, talk with, or electioneer voters in the polling place or within 10 feet of the entrance while polls are open.
- Poll workers **CANNOT** be under the influence of or consume drugs or alcohol while working. Violators are subject to removal without pay.
- Poll workers may **NOT** hold an elected office (mayor, township supervisor or commissioner, etc.) and cannot be a municipal, state or county employee.

# Poll Watcher and Candidate Guidance

Poll Watchers must show a valid, official Delaware County Watcher Certificate with a raised, embossed seal. The Watcher Certificate may list a specific precinct, but that watcher is able to visit any precinct where that candidate or party is on the ballot.

- Poll watchers are allowed to ask the poll workers (preferably the JOE) questions.
- Poll watchers must keep a respectful distance from voters, especially where they are marking the ballot.
- Allow only one watcher per candidate or party in a precinct at any time. (There can be a poll watcher for Candidate A, another for Candidate B, but **NOT** two watchers for Candidate A in the same precinct at once.) NOTE: If the number of watchers is interfering with an orderly election, the JOE may set reasonable limits so that both political parties are represented.
- Poll watchers may leave and return.
- Poll watchers may keep a list of voters. Poll watchers may inspect or photograph the Numbered List of Voters – but only while supervised and when their inspection does not slow down or interfere with the voting process.
- Challenges to voter’s identity or residence **MUST** be made in good faith. See page **61**.
- Candidates may NOT be poll watchers in a polling location where they are on the ballot.
- Candidates may only be present in the polling location during opening and closing procedures and while voting.
- Candidates may ask for the count once the polls are closed.

## Poll Watcher Removal

A Judge of Election is required by law to remove a watcher who engages in any activities that are prohibited in the Campaign-Free Zone:

1. The watcher becomes abusive or needlessly argumentative.
2. The watcher repeatedly challenges voters’ rights to receive a ballot without cause or makes challenges based on party affiliation, race, gender, age or ethnicity.
3. The watcher engages in electioneering within the polling place or within 10 feet of entrance.
4. The watcher wears any clothing or other item that promotes a candidate or party or displays an election slogan inside the polling place or within 10 feet of entrance.
5. The watcher takes photos or videos of voters or workers.
6. The watcher marks, alters or destroys any official election records or touches records without permission.
7. The watcher reviews or accesses the contents of ballot boxes and other election records.
8. The watcher interferes with the orderly process of voting, which includes but is not limited to blocking the entrance, asking for ID and disseminating false or misleading information.

**Once removed for cause, that watcher may NOT return.**





# POLL OPENING & SETUP

## PREPARING YOUR POLLING PLACE

- ❖ ALL precincts will use Poll Pads.
- ❖ Do **NOT** unseal the baby-blue bag containing the paper poll books and the supplemental pages unless the Voter Registration (Voter Reg) or Poll Worker Hotline authorizes it.
- ❖ Poll workers should arrive at 6:00AM to open the polls by 7:00AM. Call the Equipment Warehouse and the Poll Worker Hotline if the location is not open at 6:00AM. JOEs will be given precinct location contact information prior to Election Day.
- ❖ Poll watchers and candidates are permitted to remain in the precinct during opening. They must not disrupt the poll workers.
- ❖ All poll workers, including ½ day shift poll workers, **MUST** sign the Oaths, the Affidavit of Voter Identification, and the Pay Sheet.

## Precinct Overview

- The size and layout of precincts vary.
- Set up the precinct to ensure privacy at all stages of voting including checking in, marking the ballot, using the Touch Writer, casting ballots and ensuring accessibility for all voters.
- The path of travel inside the precinct should be free of hazardous conditions for all voters, including those using walkers, service animals and wheelchairs. Hazardous conditions could include chairs, power cords or any other loose objects that are in the path of travel.
- Any unsafe or hazardous conditions should be promptly reported to the Voting Machine Warehouse.
- Use the tape from the equipment cage to mark the flow of voter traffic.
- Any incidents in the polling place related to the path of travel, such as a voter or a poll worker who trips or falls, should be promptly reported to the Poll Worker Hotline.
- Use tape to mark an area about 6 feet away from the scanner to indicate the start of the scanner waiting line. Ensure the tape is positioned to maintain voter privacy.
- **NEW:** Each precinct will receive a color-coded sign in a metal stand for their precinct table where voters receive their ballot, names are added to the Numbered List of Voters, spoil ballots, etc.

## Shared Polling Place Overview

- Set up a combined check-in table with all the Poll Pads where ALL voters will check in. Voters will then be directed to their precinct to receive their ballot and cast it.
- A poll watcher must have visibility of every stage of the voting process, starting from checking in at the Poll Pad to casting their ballot, all within the same room.
- Confirm each precinct has the correct cage by checking the label located on the cage's side. If it is not your precinct's cage, call the Voting Machine Warehouse immediately.
- Be very careful reviewing the voter's Poll Pad ticket to verify you are giving them the correct precinct's ballot.
- Ballots are precinct specific. They will be accepted ONLY in the scanner for that precinct.
- Judges of Election decide how poll workers will work together and how to set up and run the polling place. Poll workers can only be paid for working in 2 precincts.

# Task List: Setting up the Precinct

- JOE confirms all poll workers have arrived. If you are missing poll workers, call or text the Poll Worker Hotline and/or the Coordinator immediately.
- Open the **White Supply Box** (inside the **Green Tote**) and find the blue Precinct Forms Checklist Folder as well as the 3 colored (*Lemon, Pink and Aqua*) Return Envelopes.
- Administer Election Board Oaths and sign both copies of the ELECTION OFFICER'S OATH OF OFFICE. The Minority Inspector swears in the JOE. The JOE swears in all other poll workers. One copy goes in the **Lemon Bureau of Elections Envelope (BOE)**, and the other goes in the **Pink Minority Inspector Envelope**. **Reminder: ANY afternoon workers MUST be sworn in by the JOE and sign both copies of the Oaths upon arrival.**
- Fill out **Lemon PAY SHEET** according to the instructions on page 18. After all workers have signed it, file the PAY SHEET in the **Lemon Bureau of Elections Envelope**. **Reminder: ANY afternoon workers MUST fill out the Lemon PAY SHEET.**
- JOE will assign tasks to poll workers and determine the layout of the precinct. If in a shared polling place, you may work together to open all precincts. Use the tape in the cage to direct voter flow and spacing for privacy.
- Verify the equipment cage is for your precinct. Call the Voting Machine Warehouse immediately, if it is NOT. Open the equipment cage and record the outer **Red Security Seal Number** on all 3 Return Sheets – Certificate 1 (Page 38) and place the seal in the **Aqua Machine Warehouse Envelope**. **IMPORTANT: If the Red Security Seal is missing or previously broken, record it on the Manifest Sheet and verify the equipment and ballots have not been tampered with.**
- Use the Manifest Sheet from the cage's door sleeve to inventory all cage supplies and note any missing or broken supplies. (Page 15) The JOE must completely fill out the Manifest Sheet with name and contact information at the top.
- Confirm the paper ballots in the cardboard ballot box/es in the equipment cage are for your precinct. Count the wrapped ballots and verify the so totals printed on the boxes are correct and that they also agree with the pre-printed total number of ballots on all 3 Return Sheets – Certificate 3.

**TIP: Ballots are wrapped in batches of 50.**  
**Do NOT unwrap ballots until needed.**

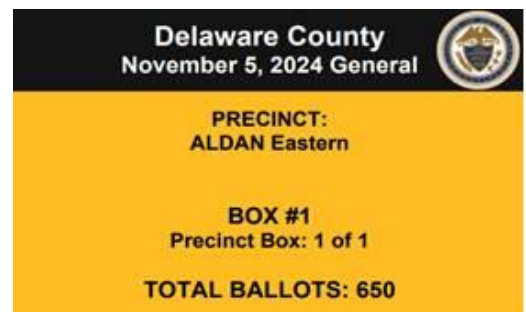

## Task List: Setting up the Precinct (Continued)

- Verify all other inventory is for YOUR precinct, including the **Green Tote, Black Pouch, White Supply Box** and their contents on pages **16-17**. If not, contact the Voting Machine Warehouse or Poll Worker Hotline.
- Unseal the Poll Pad case and confirm the blue luggage tag information matches the sticker on the Poll Pad’s printer base. Record and place the seal in the **Lime Poll Pad envelope** in the Numbered List of Voters binder. Set up the Poll Pad per instructions on page 34.
- NEW:** Each precinct is receiving a metal sign stand to assist with directing voters to the correct precinct table where voters receive ballots.
- Precincts in a shared polling location:**
  - Set up a central Poll Pad check-in table where all voters will check in on any of the Poll Pads. This table will also include pens, styluses and the yellow Affirmation of Elector forms and pink Assistance to Vote forms.
  - Set up a separate precinct table with ballots, pens, the Numbered List of Voters in the white binder, Spoiled/Remitted Envelope, privacy folders and the “I Voted” stickers.
  - Hang the precinct color-coded signs on or around the precinct table and hang the small sign on or near the scanner (see sign examples below).
  - **IMPORTANT:** The set up must allow a Poll Watcher to have clear visibility of every stage of the voting process, starting from checking in at the Poll Pad to casting their ballot, all within the same room.



- Standalone precincts will set up the voter check-in area with pens, the Poll Pad, ballots, privacy folders, forms, Spoiled/Remitted Envelope, “I Voted” stickers and the numbered list of voters in the white binder.
- Set up the Touch Writer and printer and the scanner and ballot box. Detailed setup instructions begin on page 20.
- Use green tape for taping down any cords. Use the blue tape for directing traffic flow and maintaining voter privacy.
- Record **Blue Seal Numbers** from the scanner and Touch Writer’s vDrive compartments on all 3 Return Sheets – Certificate 1. Do **NOT** remove vDrive Seals until polls are closed.

## Task List: Setting up the Precinct (Continued)

- Prominently hang all pages and sample ballots in the POSTING NOTICES envelope in the **White Supply Box** in your precinct for voters to review prior to voting. **TIP:** If wall space is limited in a shared polling location – not all notices and ballots from each precinct need to be displayed. At a minimum, post 1 complete set of notices and 1 complete set of sample ballots if all the contests are the same. **If the ballots have different contests, hang a complete set of each sample ballot.**
- Deposit all removed security seals in the **Aqua Machine Warehouse Envelope**.
- Set up privacy voting booths and any additional voting areas (tables/desks etc.) with the white plastic privacy trifolds.
- Set up the JOE table with Provisional Voting, Remitted Ballot materials, and blank poll pages.
- Using the **White Supply Box** lid, set up a return area near the scanner for pens and privacy folders.
- Complete Certificate 1 on all 3 Return Sheets has been filled out. Review that all necessary forms, reports, and seals have been properly filed in the colored envelopes per page 38.

**Doors must open at  
7:00AM sharp!**

# Item Inventory

**IMPORTANT:** The equipment cage and Poll Pad CANNOT be opened until the morning of the election with the JOE and at least one other poll worker present.

## EQUIPMENT CAGE

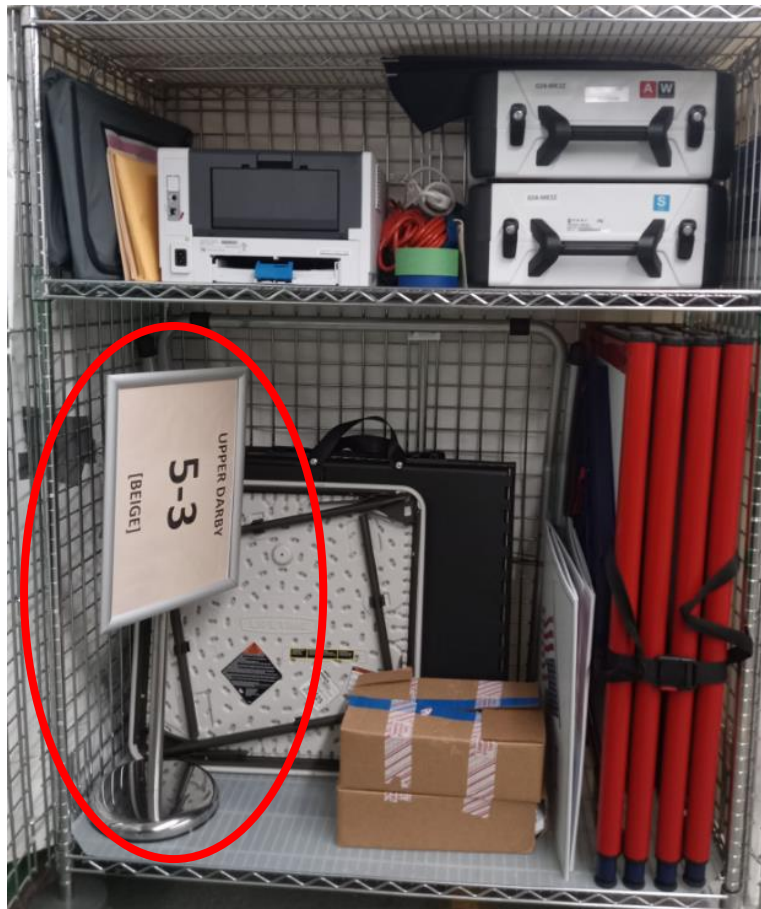

## ADDITIONAL EQUIPMENT CAGE CONTENTS

- **NEW:** Metal sign stand for all precincts. Additional laminated signs for precincts in shared polling locations.
- Manifest Sheet in the Equipment Cage sleeve to be used for inventorying purposes and noting equipment problems (See next page)
- Numbered List of Voters in White Binder with **Lime Green Poll Pad Envelope/s**
- At least 1 box of ballots per precinct

# Item Inventory (Continued)

## CAGE MANIFEST SHEET

2024 PRESIDENTIAL PRIMARY ELECTION		PRECINCT	DC_____ - SLOT#____
JUDGE OF ELECTIONS:		PHONE:	
ADDRESS:		EMAIL:	
DESCRIPTION	QTY / SERIAL NUMBER	COMMENTS	
SCANNER SERIAL #	S123456789		
SCANNER BLUE SEAL	789012		
SCANNER BLUE RETURN SEAL (IN BLUE BAG)	789013		
TOUCH WRITER SERIAL #	W901234567		
TOUCH WRITER vDRIVE COMPARTMENT BLUE SEAL	789014		
TOUCH WRITER PRINTER PORT BLUE SEAL	789015		
TOUCH WRITER vDRIVE COMPARTMENT BLUE RETURN SEAL (IN BLUE BAG)	789016		
TOUCH WRITER PRINTER PORT RETURN BLUE SEAL (IN BLUE BAG)	789017		
PRINTER SERIAL #	AK334455		
BALLOT BOX	1		
TOUCH WRITER TABLE	1		
PRINTER TABLE	1		
PRIVACY BOOTH (QUAD)	1		
PRIVACY BOOTH (SINGLE)	1		
PRIVACY SCREENS (BLACK NYLON)	4		
PRIVACY MANILLA FOLDERS	10		
PRIVACY TRIFOLDS (WHITE PLASTIC)	2		
BALLOT BAG (GREY)	1		
BALLOTS			
HEADPHONES FOR TOUCH WRITER (IN BLUE BAG)	1		
CLOSING SEAL (RED)			
CLOSING RED RETURN SEAL (IN BLUE BAG)			
PRINTER POWER CORD (IN BLUE BAG)	1		
USB CORD CONNECTS FROM TOUCH WRITER TO PRINTER (IN BLUE BAG)	1		
EXTENSION CORD	1		
POWER STRIP	1		
EXTENSION CORD (FOR POLL PAD)	1		
POWER STRIP (FOR POLL PAD)	1		
GREEN TAPE (FOR POLL PAD)	1		
THERMAL TAPE - 3 ROLLS (IN BLUE BAG)	3		
BLUE TAPE	1		
BLUE BAG	1		
MASKS			
<b>IMPORTANT NOTES FOR JUDGE OF ELECTIONS &amp; ALL POLL WORKERS</b>			
THE FOLLOWING MATERIALS ARE TO BE PLACED IN THE CAGE AT THE END OF ELECTION:			
➡ AQUA MACHINE WAREHOUSE ENVELOPE			
➡ NUMBERED LIST OF VOTERS BINDER			
➡ POLL PAD/S, EXTENSION CORD & POWER STRIP WITH GREEN LABELS			
➡ ALL UNUSED BALLOTS & BOXES INCLUDING ANY EMPTY BOXES			
ADDITIONAL NOTES:			

**TIP:** If you have any issues with equipment or supplies from the cage, please note it in the COMMENTS column. Precincts receive the same cage and equipment each election.

## Item Inventory (Continued)

### GREEN TOTE



- Election Day Guide
- **Black Pouch** (contents, see right)
- 3 Sample Ballots for each party
- **White Supply Box** (contents, see right)
- Pens for voters in large bag or boxes
- Sealed **Baby Blue bag** containing Poll Books, Supplemental Pages and directions (**Do NOT Unseal**)
- Unused Forms manila envelope containing:
  - o Yellow Affirmation of Elector forms
  - o Neon Pink Declaration of Assistance forms
  - o Blank Poll Book pages
- Used Forms manila envelope

#### Provisional Items (Contained in a large Ziploc bag)

- White Provisional Ballot Envelopes
- Green Secrecy Envelopes
- Bar coded Receipts
- 1 White Provisional Voting - Return Envelope
- Instructions

### BLACK POUCH



- Equipment Keys & ID Badge on lanyard
- Equipment Access Codes
- **White vDrive Security Return Envelope**
- **Closing Green Seal** for **Gray Ballot Bag**
- **Closing Lime Seal** for **Poll Pad**
- **Closing White Seal** for **Green Tote**

**WARNING: Do NOT break the seal on the Baby Blue bag unless Voter Registration or the Poll Worker Hotline authorizes you.**

**Opening this bag will require Voter Registration to review the entire poll book for voter history.**

**Note:** The Green Tote may be opened to review and ready materials for Election Day.



# Item Inventory (Continued)

## WHITE SUPPLY BOX

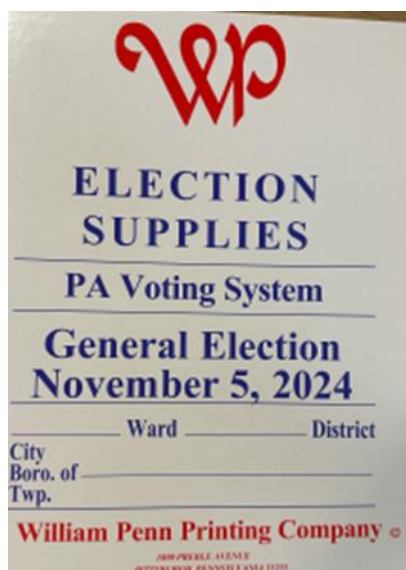

- Blue Precinct Forms Folder
  - o Lemon Pay Sheet
  - o 2 Election Officer's Oath
  - o Affidavit of Voter Identification
  - o 3 colored Return Sheets (**Aqua, Pink and White**)
- Spoiled/Remitted Ballot Manila Envelope
- Elector's Declaration to Return Mail Ballot pad
- Posting Notices Envelope
- Record of Assisted Voters
- Poll Worker Name Tags
- Statement of Complaint – Title III
- 3 colored Return Envelopes (**Lemon, Pink, and Aqua**)
- Election Day Digest
- Challenges Elector's Affidavits
- Bag with tape and pens for poll workers
- "I Voted" stickers

## POLL PAD



- Lime Green Case with Blue Luggage Tag
- Metal Flip Stand and Case
- iPad
- 2 lime styluses for poll workers
- 10 green styluses for voters
- 18" Power Cord & Brick
- Printer with roll of paper and lime green cable to attach to iPad
- Screen Cloth
- Extra roll of paper
- Lime green seal for closing
- At least one precinct in a shared location will have a white charger and cord





# EQUIPMENT SETUP GUIDE

## BALLOT PRINTER, TOUCH WRITER, SCANNER BALLOT BOX, SCANNER & POLL PAD

- ❖ Boot up times for the Touch Writer and scanner are both approximately 10 minutes. The screen will appear black at times – do not reboot.
- ❖ In shared polling places, verify the Poll Pads are properly synced.
- ❖ You may label reports for easier identification.
- ❖ Set up the precinct ensuring voter traffic flows, voters have privacy and there are no tripping hazards.

**If you encounter ANY issues during Touch Writer and Scanner setup, call the Voting Machine Warehouse at (610) 874-8780.**

**If you have Poll Pad issues, call the Poll Worker Hotline at (484) 460-3750.**

## Setting Up the Ballot Printer

1. Set up the ballot printer table next to where you will set up the Touch Writer and set the ballot printer on the table.
2. Plug in the square end of the USB printer cable from the blue bag into the printer. Note: The flat end will be plugged into the Touch Writer. [A] ▶
3. Insert the printer power cord from the blue bag into the printer and the other end into an electric outlet. **Do NOT turn on the printer yet.** The printer should be powered on ONLY after setting up the Touch Writer. [B] ▶

Printer will come pre-loaded with paper. BE CAREFUL with the extendable paper tray when unpacking and packing the printer.



## Setting up the Touch Writer

**IMPORTANT: Do NOT remove Blue Security Seal on vDrive compartment until polls close.**

1. Remove the Touch Writer stand from the cage. Release bungee cords. Pull on the handle and lift and lock the legs into place. [C] ▶
2. Pick a location that does not create a tripping hazard with the power cords.
3. Place the Touch Writer on top of the stand, aligning footpads with the table's indentations. The handle on the front of the Touch Writer must face the same direction as the handle on the stand. [D] ▶

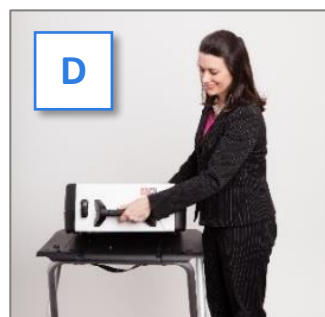
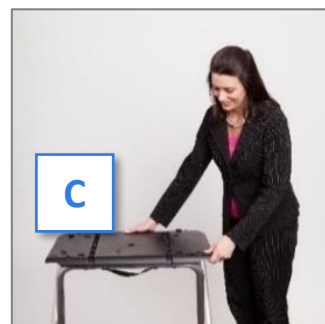

- Stand at the front of the stand. Reach under the front of the stand top and push the latch away from you to secure the Touch Writer to the stand. Check that the Touch Writer is attached by trying to lift it up. [E] ▼



- Open the case and remove the power brick and power cord from the storage compartment. [F] ▶

**IMPORTANT: Do NOT remove the *Blue Security Seal* from the vDrive compartment until closing. Record the seal's number on all 3 Return Sheets' Certificate 1.**

Close the compartment and case.

- Plug the power cord into the power brick [G]. ▼ Slide the base of the black connector molding back [H] and then plug it into the back of the Touch Writer (flat side up). [I] ▼

**IMPORTANT: Do NOT plug the power cord into an outlet yet.**



- Remove the *Blue Security Seal* from the printer port on the back of the Touch Writer, [J] ▼, and record the security seal number on all 3 Return Sheets' Certificate 1. Place the seal in the *Aqua Machine Warehouse Envelope*.
- Plug the flat end of the USB printer cable from the ballot printer into the back of the Verity Touch Writer, with the notch facing up. [K] ▼

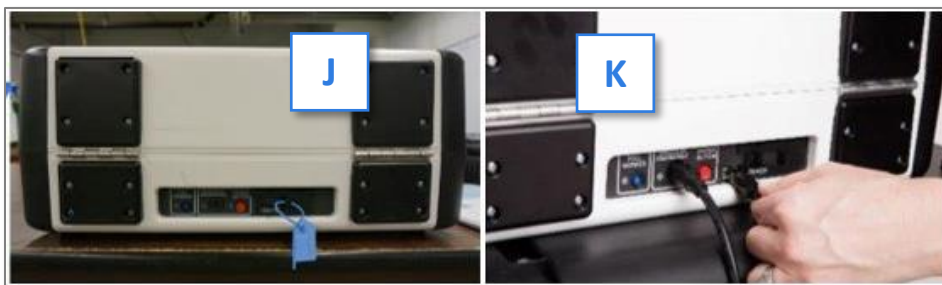

9. Open the Touch Writer case and lock the lid brace in place. [L] ▶

**IMPORTANT:** Never tilt a device up by the handle while cords are connected – this can damage the cord where it connects to the device, or cause damage to the device itself.



10. Unlock [M] using the key from the **Black Pouch**, unlatch [N], and remove tablet [O]. ▼



11. Seat the tablet in the cradle [P], tilt it back [Q], and lock it in place [R]. ▼



12. Attach privacy screens to both sides of the stand. [S] ▶



12. Plug the power cord into AC power. A green light will illuminate on the power brick when AC power is present.

13. Press the switch on the bottom right side of the *ballot printer* to power it on. [T] ▶

**IMPORTANT: Do NOT move onto the next step until the printer is powered on!**



14. Press the **Red Power Button** on the back of the Touch Writer to power it on. [U] ▶

A Power-On Self-Test report will automatically print on Touch Writer's built-in report printer. This report will indicate any hardware or connection issues. If any issues are noted, call the Voting Machine Warehouse at **(610) 874-8780**.



File the unsigned Power-On Self-Test report in the **Aqua Machine Warehouse Envelope**.

## Touch Writer Screen Orientation

Once powered up, the Touch Writer will display the Print Zero Report screen. [V] ▶

Please review the information bar [W] ▼ at the bottom of the screen which includes the date and time, plus the following:

- **Ballots:** The number of ballots printed using the Touch Writer for the current election should be zero.
- **Lifetime:** The number of ballots printed using the Touch Writer for the lifetime of the device (for all elections).
- **AC and battery power indicators:** A green battery icon indicates the battery is connected; a green plug icon indicates AC power is connected. Specific battery power level can be found on the Touch Writer Power-On Self-Test report. The battery does NOT recharge when plugged in. **See page 91 for more information on battery power under Loss of Power.**

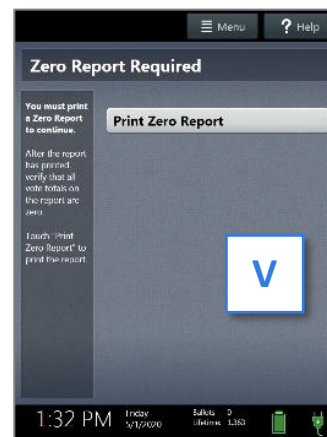

Verify the displayed information is correct and the Touch Writer is running on AC Power. ▼

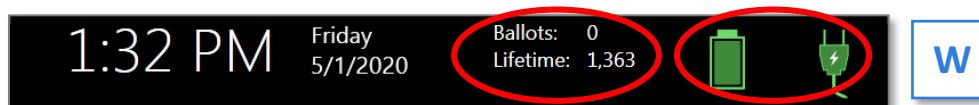

# Opening the Polls

**IMPORTANT:** If the ballot count total, precinct, or clock are incorrect, or the Touch Writer is not running on AC Power or the battery is low, contact the Voting Machine Warehouse at (610) 874-8780.

1. Select **Print Zero Report**. Print two (2) copies of the Zero Report. Using the Zero Report, check the following: [X] ▶
  - Verify the ballot count total on the Zero Report is ZERO.
  - Verify that the polling place on the report is correct.
  - Use the Zero Report information to fill out all three Return Sheets with the Touch Writer serial number and lifetime counter on Certificate 1 (see page 38).
  - File one (1) signed report in the **Pink Minority Inspector Envelope** and the other signed report in the **Aqua Machine Warehouse Envelope**.

2. Select **Open the Polls** [Y] ▶

**IMPORTANT:** Once you open polls, you can no longer print a Zero Report.

3. Enter the **Open Polls Code** from the **Black Pouch**, and then select **Accept**. The Open Polls Report will automatically print. [Z] ▶
4. Sign and file the Open Polls Report in the **Aqua Machine Warehouse Envelope**.

**The Touch Writer is now ready to be used by voters!**

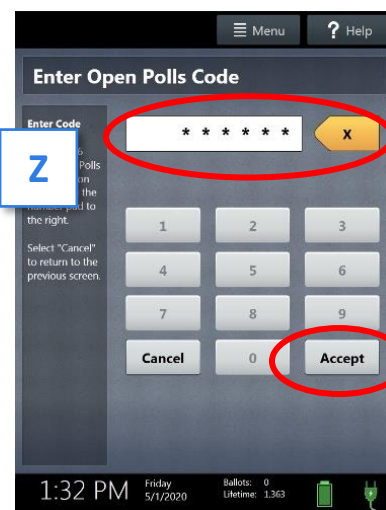
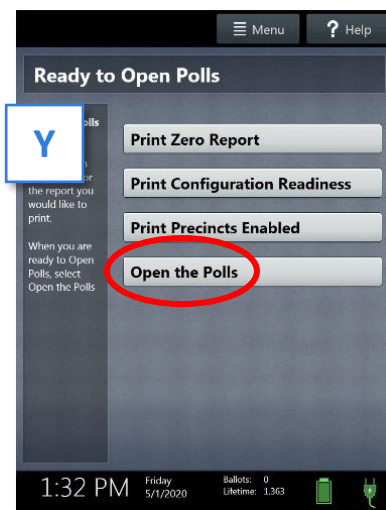
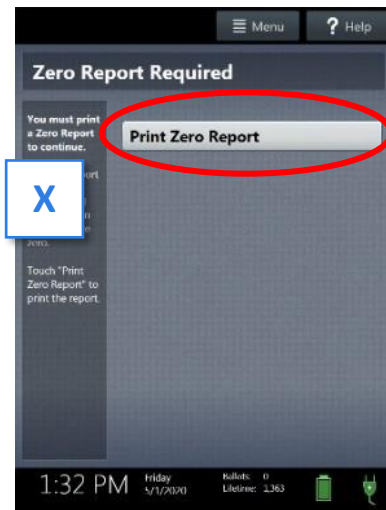



# Scanner Overview



The scanner is a polling place-based digital scanner for scanning and casting paper ballots.

The scanner can be used with hand-marked paper ballots or with paper ballots marked by and printed from the Touch Writer.

The scanner deposits scanned paper ballots into its ballot box and **Gray Ballot Bag** for secure storage. It will not accept paper ballots from other precincts, Provisional ballots or mail-in/absentee ballots.



**vDrives** are used to transfer digital ballot styles from the Verity election definition software to the scanner, and to transfer voted paper ballots from the scanner to Verity software for tabulation.

vDrives are inserted into a standard USB port located in a locked and sealed compartment; each scanner and Touch Writer has its own vDrive.

Note: Software startup for each unit may take several minutes, due to security and data integrity checks that the Verity software performs. This process is included in the design of the Verity Voting System to verify the authenticity of the software before allowing it to operate.

## Setting up the Ballot Box

1. Position the folded ballot box as shown below. [A] ▼
2. Unlatch the four clips (two on each side). [B] ▼
3. Pull open the ballot box. [C] ▼
4. Press the side panels outward until they are flat, being careful not to pinch your hands or fingers. [D] ▼
5. Lower the bottom panel but do **NOT** press down. [E] ▼

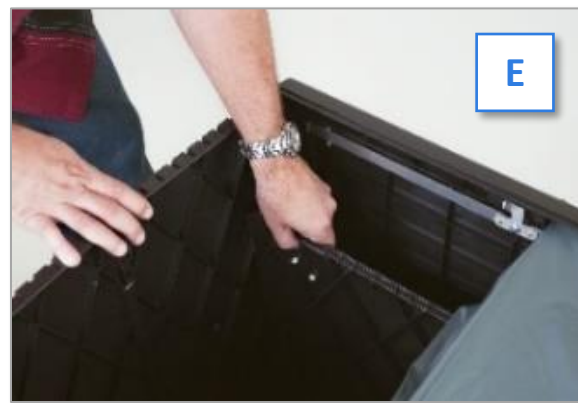
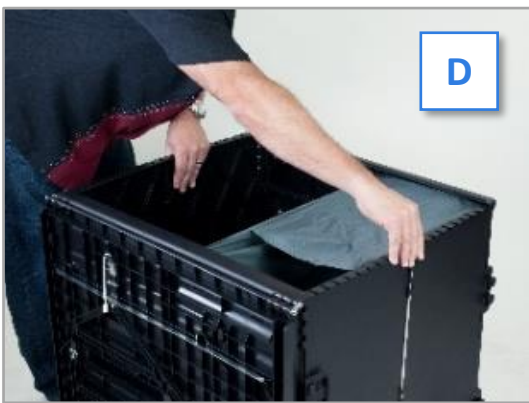
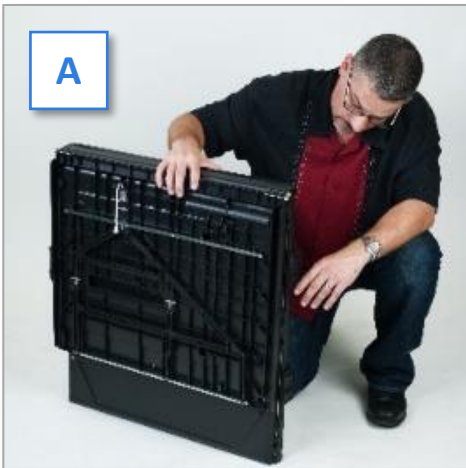

## Setting up the Ballot Box (Continued)

6. Release the lid by unhooking the 3 black straps. [F, G] ▼



7. Pull the string on the underside of the lid upward to unlock the lid latch. [H, I] ▼

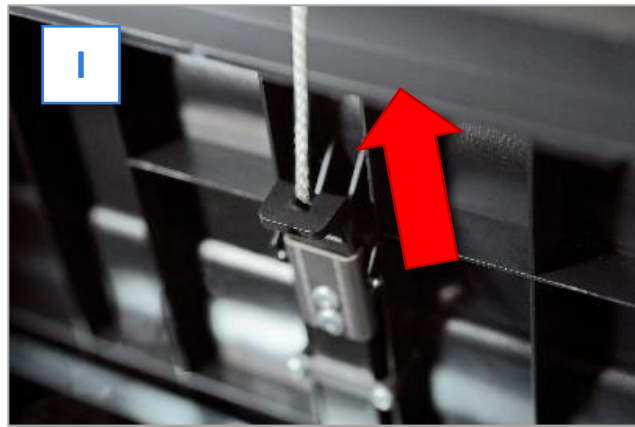
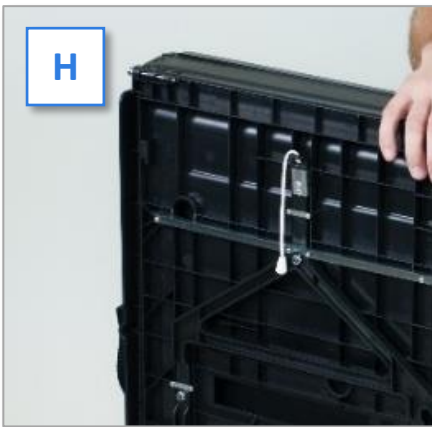

8. Lift the lid while gently pulling upward and outward, ensuring that the double hinge is fully extended. Lay the lid across the top of ballot box, and then press it down. Do **NOT** force it. [J, K, L] ▼

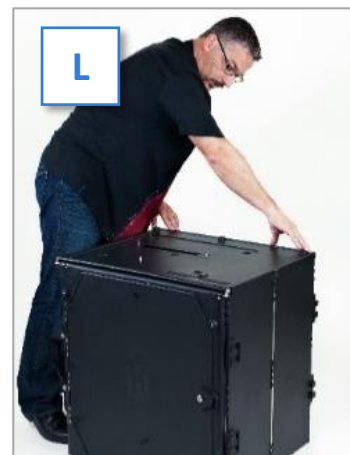

## Setting up the Ballot Box (Continued)

9. Unlock the front door with the ballot box key from the **Black Pouch**. [M] ▼

10. Press firmly on bottom panel to lock it in place. [N] ▼



11. Assemble folded **Gray Ballot Bag**. Ballot bags will have **precinct labels** in the clear sleeve on top of the bag and on the side with the handle. Verify the labels are for the correct precinct. [O] ▼ **DO NOT REMOVE THESE LABELS.**



12. Place the unzipped ballot bag inside the ballot box so the side with the handle and label is facing outward and the bag is snug against the side.

13. Position the ballot box near an electrical outlet. Do not create a tripping hazard. Keep the voter's privacy in mind.

# Setting up the Scanner

**IMPORTANT: Do NOT remove Blue Security Seal on vDrive compartment until polls close.**

1. Place the scanner on the assembled ballot box, aligning its footpads with the indentations. The handle on the scanner must face the front of the ballot box. [A] ▼
2. Reach inside the ballot box and pull the cord down and away from you to lock the lid and the scanner in place. Check that the scanner is locked in place by trying to lift it up. [B] ▼
3. Close and lock the front ballot box door with the key from the black pouch. [C] ▼
4. Open the scanner case and remove the power brick and power cord from the storage compartment. Close the compartment and case. [D] ▼

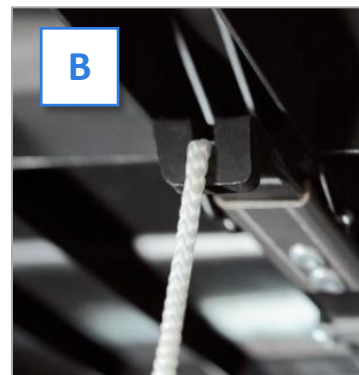

5. Plug the power cord into the power brick [E]. Slide the base of the black molding back and then plug the power brick into the back of the scanner (flat side up). [F] ▼

**IMPORTANT: Do NOT plug the power cord into the outlet yet.**



## Setting up the Scanner (Continued)

- Open the scanner case and lock the lid brace in place [G], then unlock the case [H], unlatch the case [I], and remove [J] the tablet. ▼

**IMPORTANT: Never tilt a device up by the handle while cords are connected – this can damage the cord where it connects to the device, or cause damage to the device itself.**



- Seat the tablet in the cradle [K], tilt it back [L], and lock it in place [M]. ▼



## Setting up the Scanner (Continued)

8. Attach privacy screens to each side of the ballot box. [N] ▼



9. Plug the power cord into AC power. A green light will illuminate on the power brick when AC power is present.
10. Press the **Red Power Button** on the back of the scanner to power it on. [O] ▼

The Power-On Self-Test report will automatically print on scanner's built-in report printer. This report will indicate any hardware or connection issues. If any issues are noted, call the Voting Machine Warehouse at **(610) 874-8780**.

File the unsigned Power-On Self-Test report in the **Aqua Machine Warehouse Envelope**.



# Scanner Screen Orientation

Once powered up, the scanner will display the **Print Zero Report** screen. Please review the information bar at the bottom of the screen which includes the date and time, plus the following: [A] ▶

- **Ballots:** The number of ballots scanned and cast on the scanner for the current election should be zero. [B] ▼
- **Sheets:** The number of ballot sheets scanned on the scanner for the current election should be zero. [B] ▼
- **Lifetime:** The number of ballots cast on the scanner for the lifetime of the device (for all elections). [B] ▼
- **AC and battery power indicators:** A green battery icon indicates the battery is connected; a green plug icon indicates AC power is connected. Specific battery power level can be found on the Scanner Power-On Self-Test report. The battery does NOT recharge when plugged in. [B] ▼ **See page 90 for more information on Battery Power under loss of power.**

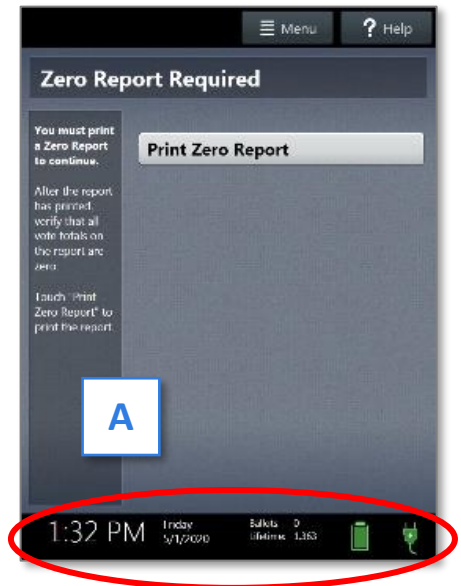

Verify the displayed information is correct and the scanner is running on AC Power.



# Opening the Polls

**IMPORTANT: If the ballot count total, precinct, or clock are incorrect or the scanner is not running on AC Power or the battery is low, contact the Voting Machine Warehouse at (610) 874-8780.**

1. Select **Print Zero Report** [C] ▶ and print **two (2)** copies of the Zero Report. Using the Zero Report, check the following:
  - Verify the ballot count total on the Zero Report is **ZERO**.
  - Verify that the polling place on the report is correct.
  - Use the Zero Report information to fill out all three (3) Return Sheets with the scanner serial number and lifetime counter on Certificate 1 (see page 38).

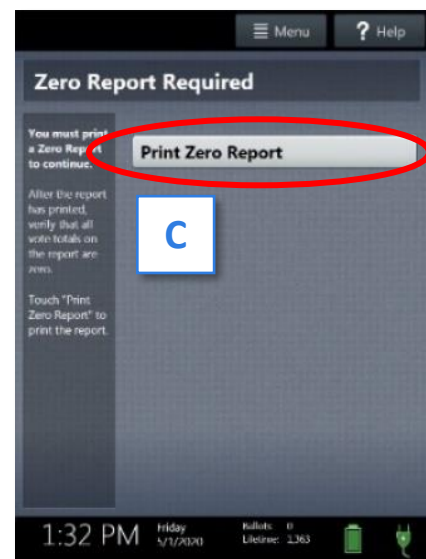



## Opening the Polls (Continued)

2. File one (1) signed Zero Report in the *Pink Minority Inspector Envelope* and the other signed Zero Report in the *Aqua Machine Warehouse Envelope*.
3. Select **Open the Polls**. [D] ▼
4. Enter the **Open Polls Code** from the *Black Pouch*, and then select **Accept**. The Open Polls report will automatically print. [E] ▼
5. Sign and then file the signed Open Polls reports in the *Aqua Machine Warehouse Envelope*.

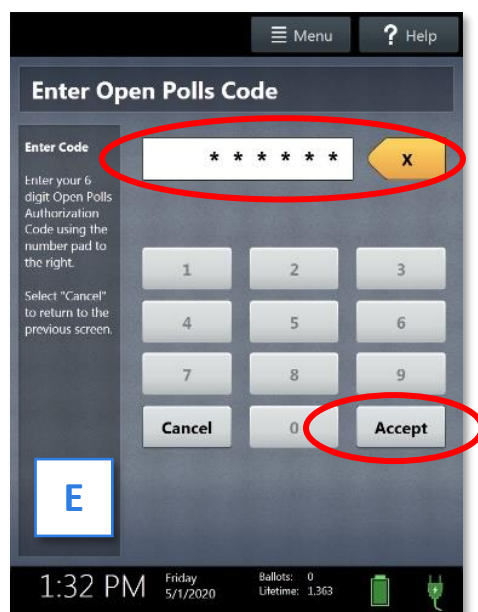
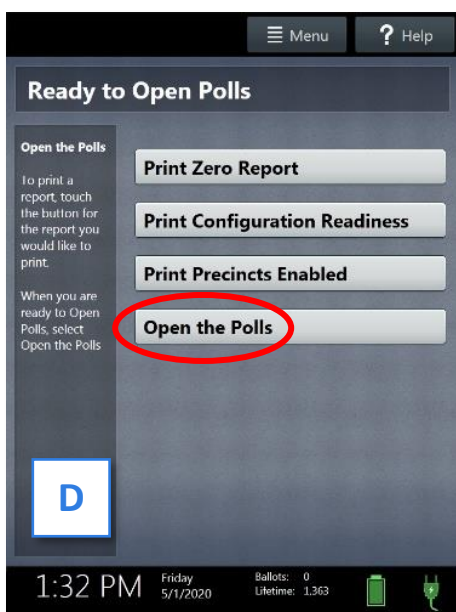

**The scanner is now ready to be used by voters!**

# Poll Pad Setup

What is a Poll Pad? Poll Pads are electronic poll books also referred to as e-pollbooks. They replaced the blue poll book and the supplemental pages. The information on each Poll Pad will contain the latest information on Delaware County's entire 400,000+ voter registration.

They allow for faster check-in, the ability to direct voters to their correct precinct, search for voters by birthdate and address, consistent voter instructions and enhanced transparency.

With the Poll Pad, you can check in voters from any precinct in a shared room. It will log that voter as checked in at all the Poll Pads in the same room. It will not allow you to check in voters from other precincts in different rooms or locations. If the voter is at the wrong precinct, a ticket with the correct precinct's address can be printed.

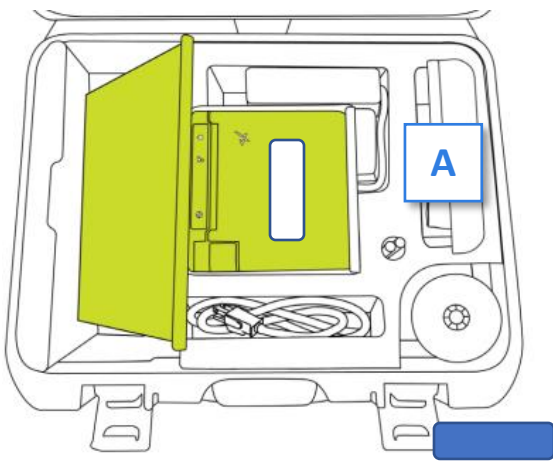

1. Verify the case's blue luggage tag matches the sticker on the printer.
2. Drape the power cord and the green cable over the right side of the case, then gently lift the entire Poll Pad kiosk out of the case using both hands and stand up on the printer base. [A]

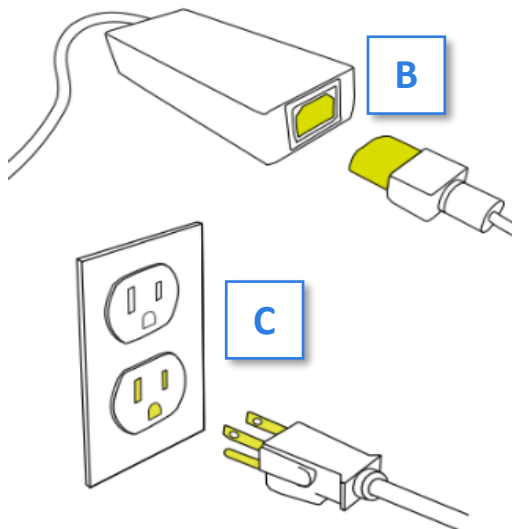

3. Securely connect the power cord into the adapter located on the long printer cord. [B]

Next, plug the power cord into a wall outlet or extension cord. [C]

## Poll Pad Setup (Continued)

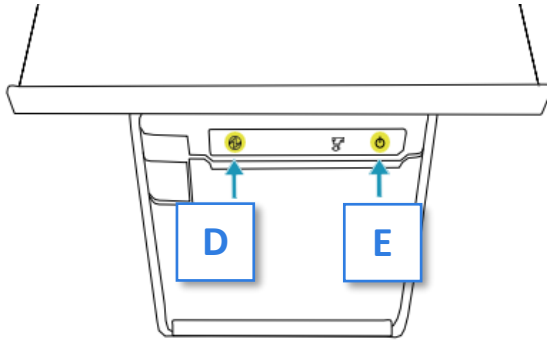

4. A blue light indicates the printer is powered on. [D]

If there is no blue light, push the power button 1 time. [E]

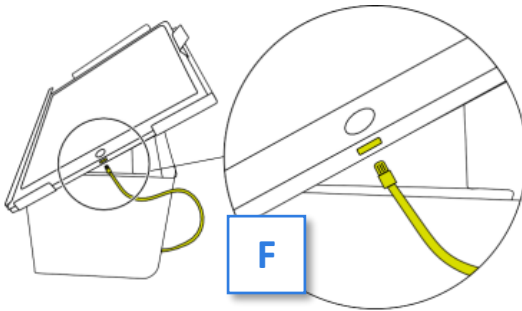

5. Plug the green cable into the charging port located on the right side of the Poll Pad. [F]

The Poll Pad should power on automatically.

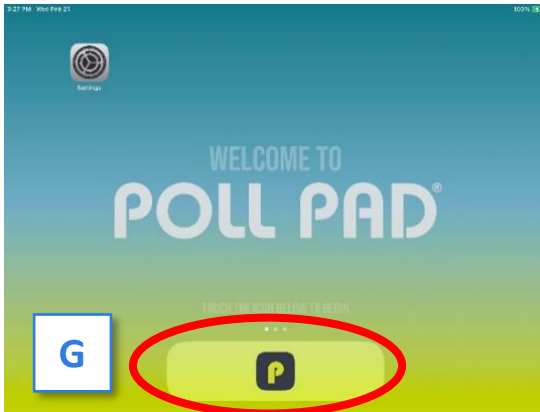

6. Press the application icon at the bottom of the screen [G] to open Delaware County's homepage.

TIP: Do NOT use Wet Wipes or any liquids on the screen. Use only the supplied screen cloth.

# Poll Pad Setup (Continued)

**IMPORTANT: All examples are from the training base; therefore, the top bar is purple. On Election Day confirm the top bar is navy blue and you CANNOT reset the base.**

Call the Poll Worker Hotline immediately at (484) 460-3750 if your Poll Pad is in training mode.

7. Verify the following is correct:
  - Polling place [H]
  - Check-in Count = 0 [I]
  - Battery life is close to full (90% or greater) See page 95 to charge. [J]
  - Name of jurisdiction [K]
  - Election name and date [L]

**Call the Poll Worker Hotline if H through L is wrong.**

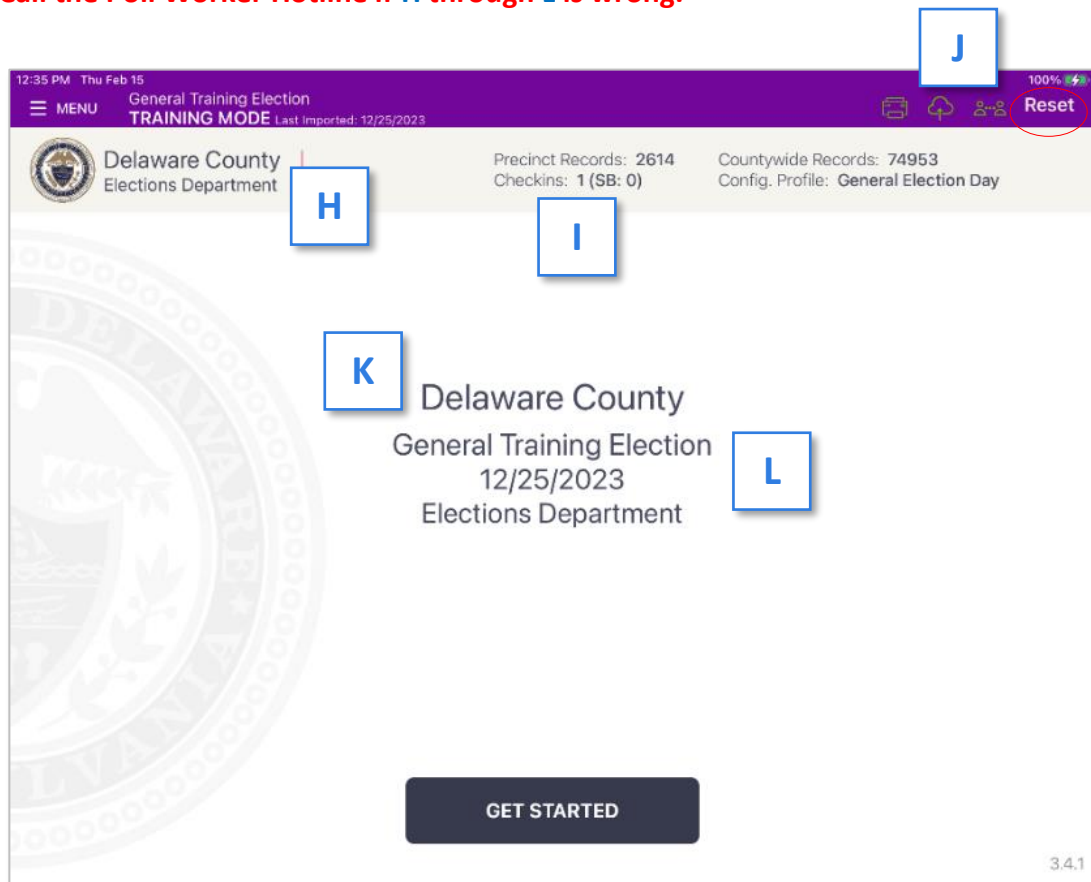

## Poll Pad Setup (Continued)

- Verify the multi-peer icons correctly reflects the setup of your polling place. For instance, if your polling place has 3 total precincts – your Poll Pad would indicate it is syncing with 2 in the red circle. [M] Call the Poll Worker Hotline if this number is incorrect.

### MULTI-PEER ICONS



Poll Pad is currently connected and synchronizing with the other precinct Poll Pads.

[M]



The number inside the red circle indicates the number of precinct units the Poll Pad is connected to.



Poll Pad recognizes the presence of other precinct Poll Pads but is not connected or synchronizing with these units.



Poll Pad is currently disconnected and not synchronizing with the other precinct Poll Pads. **Contact the Poll Worker Hotline.**

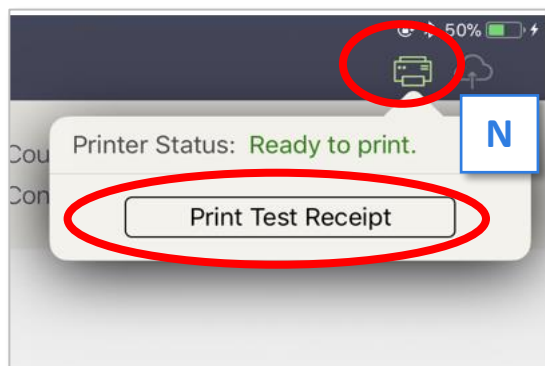

- Verify the paper is properly loaded. Tap the Printer Icon then tap Print Test Receipt bar. [N] If the test receipt prints properly, i.e., it did not jam – file the test receipt in the **Lime Poll Pad envelope**. [O] If the paper jams, see page 95 to resolve.

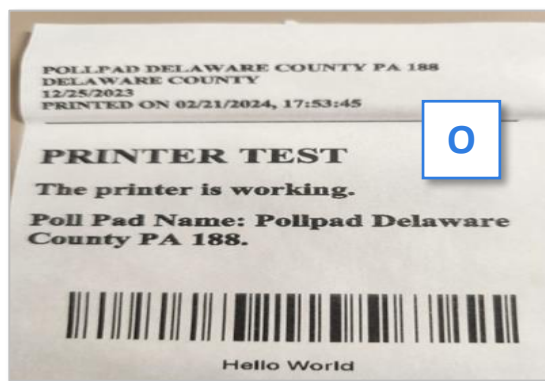

- Use the **Green Tape** from the cage to tape down any loose cords.

**IMPORTANT: The County does not call these receipts – they are TICKETS. This screen is hard coded on the Poll Pad and unchangeable. This is the only time we will use the term receipt.**

**The Poll Pad is now ready to be used by voters.**

# Filling out the Return Sheets: Certificate 1

All 3 certificates are located on the large *Pink, Aqua and White Return Sheets* (see page 79). There are no individual certificates.

There are 3 Return Sheets included in the paperwork which must each be filled out completely, legibly and identically.

Certificate 1 is a record of Poll Opening security measures. Use these instructions, along with the infographic on the opposite page, to fill out Certificate 1.

- Record the seal numbers from **Blue Security Seals** on the vDrive compartments inside the scanner and the Touch Writer. These seals are **NOT** removed until polls are closed.
- Record the serial numbers (abbreviated S/N) from the Open Poll Reports for both the scanner and the Touch Writer. These should agree with the Manifest Sheet.
- Record the Lifetime Counter numbers from the Open Polls Reports for both the scanner and the Touch Writer.
- Record the seal number from the **Red Security Seal** removed from the equipment cage. Place the seal in the **Aqua Machine Warehouse Envelope**.
- Record the seal number from the **Blue Security Seal** removed from the back of the Touch Writer. Place the seal in the **Aqua Machine Warehouse Envelope**.
- JOE and all present poll workers **MUST** sign all machine reports except the Power-On Self-Test reports.
- Place both the scanner and the Touch Writer's Power-On Self-Test Reports in the **Aqua Machine Warehouse Envelope**.
- Place one (1) Zero Report from both the scanner and the Touch Writer in the **Aqua Machine Warehouse Envelope**.
- Place one (1) Zero Report from both the scanner and the Touch Writer in the **Pink Minority Inspector Envelope**.
- Place the Open Polls Report from both the scanner and the Touch Writer in the **Aqua Machine Warehouse Envelope**

# Filling out the Return Sheets: Certificate 1

POLL OPENING - CERTIFICATE 1			
Before opening the polls, record these numbers from the equipment and the tapes. Verify all "Zero & Open Polls Report Tapes" show zero votes cast. Call warehouse if incorrect.			
ELECTION EQUIPMENT	BLUE Seal Number vDrive Compartment <i>Unseal at Poll Closing</i>	Serial Number from Machine Tape	Lifetime Counter from Machine Tape
Verity Ballot Scanner	1 0005224	2 1903221810	3 5689
Verity TouchWriter	0054557	4 1913547412	5 77
RED Seal # on Cage:	6 0005226	BLUE Seal # Back of TouchWriter:	7 003546



Blue Security Seals from both vDrive Compartments.  
DO NOT REMOVE UNTIL POLLS CLOSE

**Election Header**

Poll Worker Training - General  
Election Date: 10/31/2021  
Delaware County, Pennsylvania  
Delco Elementary School  
Election Day

**Verity Scan**

S/N: S1903221810 ← 2  
Version: 2.3.1

Ballot Counter: 0  
Lifetime Counter: 3 → 5689

**Open Polls Report**

**Election Header**

Poll Worker Training - General  
Election Date: 10/31/2021  
Delaware County, Pennsylvania  
Delco Elementary School  
Election Day

**Verity Touch Writer**

S/N: W1913547412 ← 4  
Version: 2.3.4

Ballot Counter: 0  
Lifetime Counter: 5 → 77

**Open Polls Report**

"Zero" & "Open Polls" Report Tapes from Scanner and TouchWriter  
NOTE: Ballot Counter is ZERO.

Remember to sign the bottom of all machine tapes where indicated.

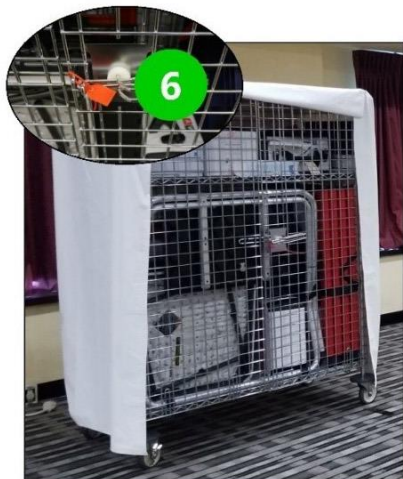

Equip. Cage with Red Security Seal  
Removed when opening the cage.



Blue Security Seals from Printer Port on TouchWriter (rear near power button). Removed when setting up.

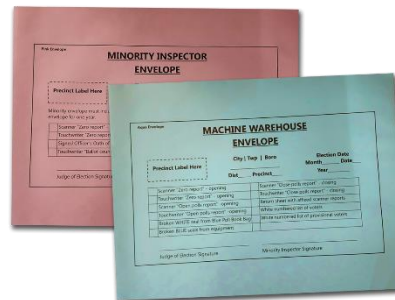

---

PAGE INTENTIONALLY LEFT BLANK  
USE PAGE FOR NOTES





# WORKING WITH VOTERS

## ENSURING A GREAT VOTER EXPERIENCE

- ❖ **Precincts will NOT receive Provisional Ballots. ALL Provisional Ballots will be printed on the Touch Writer and are NOT scannable.**
- ❖ **Do NOT open the sealed baby blue bag containing the paper poll books without authorization from Voter Registration. If the bag is opened accidentally, the book must be thoroughly reviewed to verify no activity was recorded.**
- ❖ ANY voter may use the Touch Writer, if requested.
- ❖ **IMPORTANT:** Never deny a citizen the right to vote. If you cannot contact Voter Registration within a reasonable amount of time to verify a person's eligibility, have them vote by Provisional Ballot.
- ❖ Throughout the day, compare the numbered list of voters to the number of ballots scanned to verify the precinct's numbers agree.
- ❖ Keep phone usage to a minimum.
- ❖ **NEW:** Appendix B: De-Escalation Tips, see page 90.

## Voter Check In Overview

- All voters will check in at Poll Pads. At shared polling places, voters may check in at ANY Poll Pad. If your precinct is larger or busy, use tape to manage traffic.
- If resolving a voter's issue requires a call to the county for more information, pull that voter from the line to work with the JOE to resolve the issue so that you may continue serving other voters.
- Control the flow of voters at the check-in table to prevent overcrowding at available voting booths.
- The balloting area MUST offer privacy, accessibility, and adequate lighting.
- **NEW:** You may write the number from the numbered list on the Poll Pad ticket to keep them straight and to assist in line management.
- **IMPORTANT:** If at any point a voter becomes angry or upset, try to move them to a quieter area and do the following: remain calm and actively listen. Do NOT debate. Be non-confrontational. Do NOT cross your arms. Offer what can be done. See De-escalation Tips in Appendix B, page 90.

### Voters may:

- Talk respectfully among themselves.
- Take "I Voted" pictures or "selfies" that do not include other voters, other voters' ballots or the poll workers.
- Use their phones to research candidates for their own personal purposes.
- Wear clothing or accessories with political messaging.
- Deliver their sealed mail-in ballot to a secure Delaware County Drop Box by 8:00PM on Election Day.

### Voters may not:

- Remove ballots from the precinct to fill out elsewhere.
- Engage in politicking inside the precinct.
- Intimidate other voters.
- Take photos of other voters or poll workers. Privacy and safety must be respected.
- Leave the polling place before voting once they have signed the Poll Pad (or poll book, if needed) unless they want to forfeit their vote.
- Leave their sealed mail-in ballot with a poll worker and expect it be counted.

# Poll Pad: Voter Check-in Procedure

This section will review checking in a voter with no messages or exceptions. Note: These examples are from the test database.

**If the Poll Pad stops working, call the Poll Worker Hotline immediately!**

1. Greet the voter. Ask the voter for their name. Repeat the name aloud for any poll watchers.
2. Using the stylus, tap **GET STARTED** [A]
3. Search for voters by using their last and first name. Use the on-screen keyboard to enter the first 3 letters of the voter's last and first names, and then tap **Search**. [B]

- Use the Rule of 3's – it maximizes the search and minimizes typing errors.
- If they have a name like D'Adam or Mc Cloud – only type up to the special character or space.
- Use the stylus, not your finger. It keeps the screen cleaner.

4. IMPORTANT: If "No Records Found" appears, tap **OK**, [C], clear both name boxes, select **ADVANCED OPTIONS**, [D], choose and enter the voter's Date of Birth (DOB), [E], and then tap **Search** (There are other Advanced Options; however, the address must be entered identically to their record to be located. So, we suggest using the DOB).

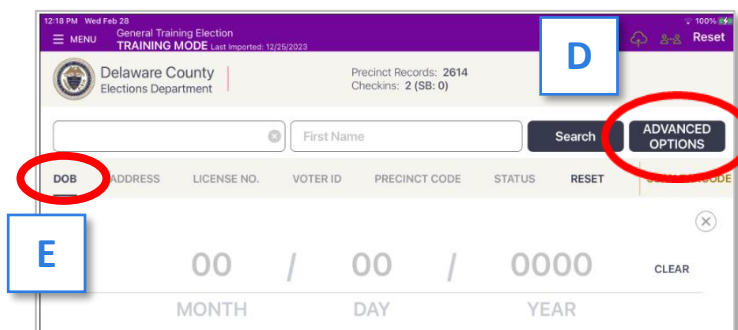
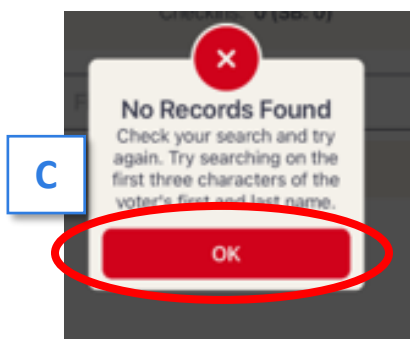
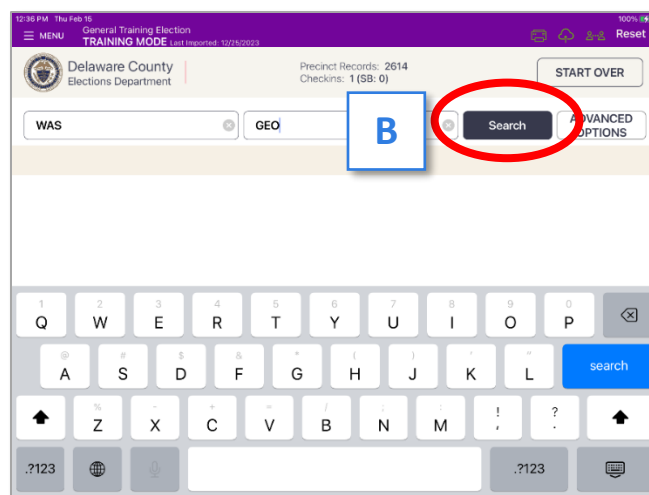
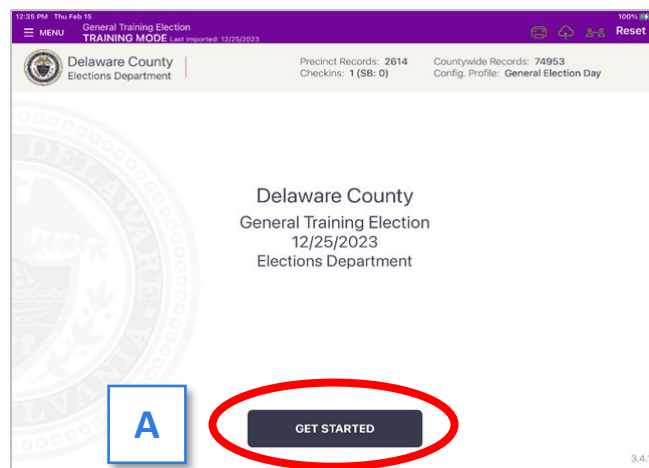

# Poll Pad: Voter Check-in Procedure (Continued)

5. Select the voter's record that matches the voter's name. [F]

- Note out-of-precinct voters will be shaded gray with the message "Wrong Location." [G] See page 54 for directions.

6. Ask the voter to verify their address AND birthdate. If both are correct, tap ACCEPT. [H]

- If it is the correct voter, but wrong address, see page 51 before proceeding.
- If it is the wrong voter and you cannot find the voter, see page, see page 52.

7. Flip the screen towards the voter. Ask the voter to sign the screen with their finger or stylus. [I]

Once the voter is satisfied with their signature, flip screen back and tap DONE SIGNING. [J]

**IMPORTANT: PAY ATTENTION!** Delco's entire voter registration database is loaded on EVERY Poll Pad.

8. The Poll Worker Confirmation page will appear. Review the page for accuracy. Verify the voter has signed the correct record. **AVOID** checking in the wrong voter.

9. Initial in the box [L] and tap **SUBMIT**. [L] See page 58 if checked in wrong voter.

Remember: If the voter's signature bears no likeness at all to the signature on file, they confirmed their address, birthdate and signed the Poll Pad with the stylus or their finger.

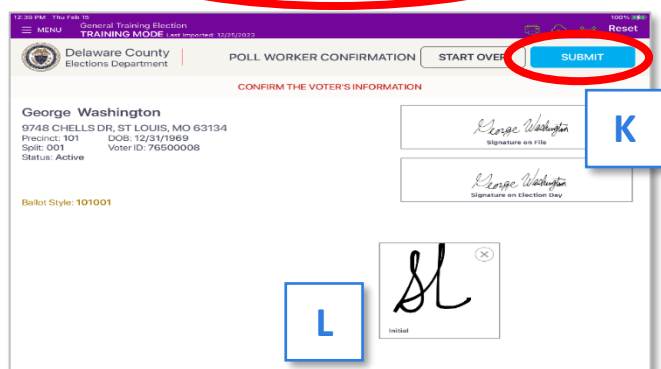
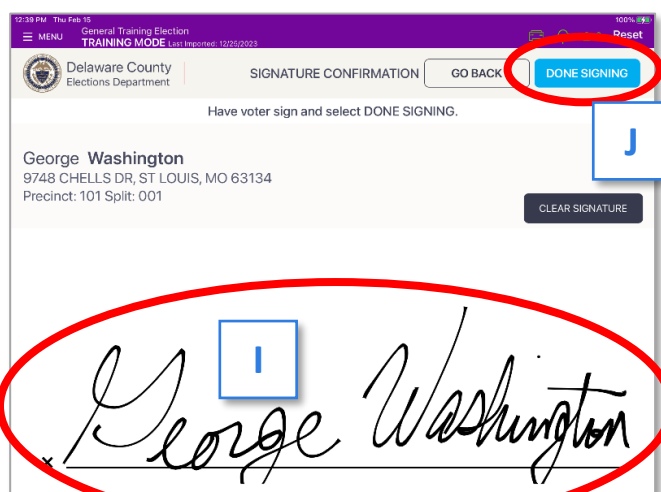
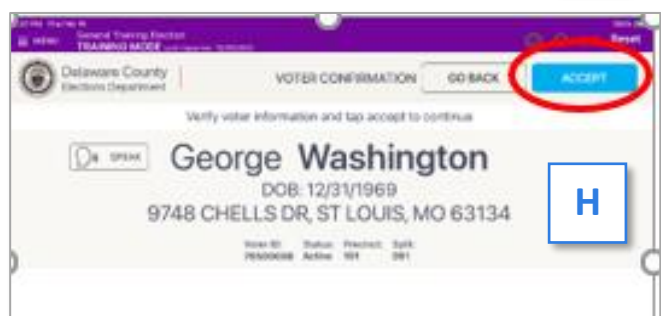
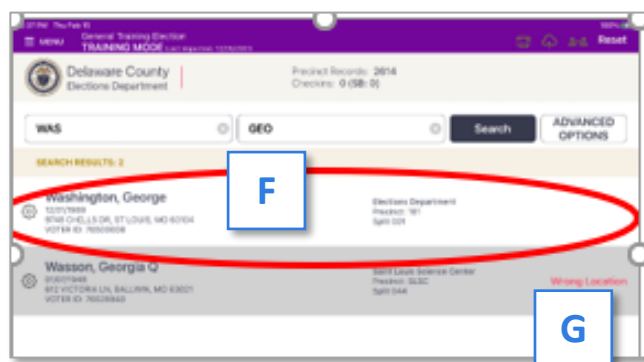

# Poll Pad: Voter Check-in Procedure (Continued)

10. The voter has been successfully processed and the Poll Pad will now print their ticket. If the voter checked in at a shared polling place, all the synced Poll Pads will automatically update that they have voted.

**IMPORTANT:** The voter's record will now show **Voted**, [M]. The voter has not cast their vote – they have only checked in which is equivalent to signing the paper poll book. The voter cannot leave the precinct and return to vote. If the voter leaves the precinct, they forfeit their opportunity to vote. Make a note of any votes forfeited on the Return Sheets' Note Box and include a note in the BOE envelope.

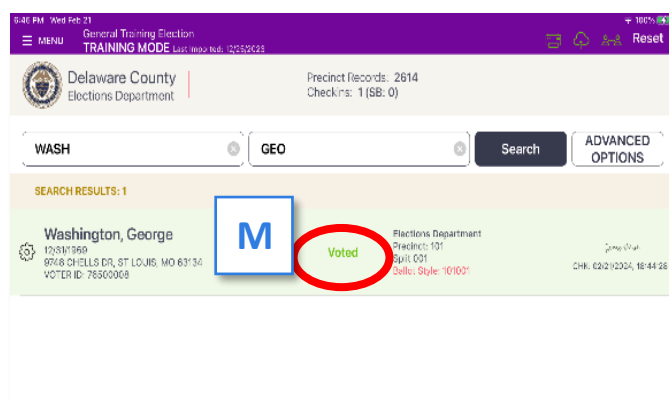
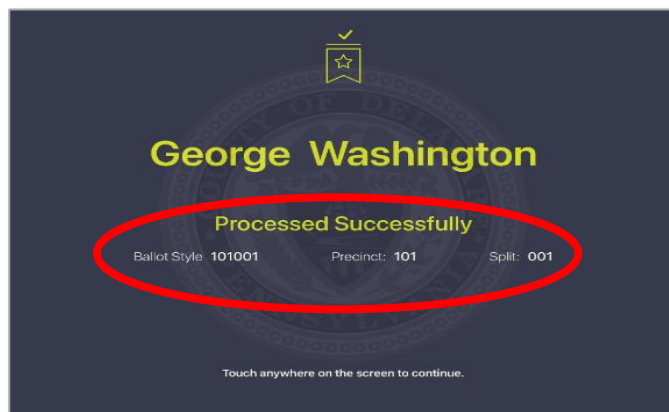

11. Give the voter their ticket.

- At single precincts, the voter will continue moving down the check-in table.
- In shared polling places, direct the voter to the correct precinct table to receive their ballot. To aid with identifying the correct precinct, each precinct has been assigned a color [N], indicated on the ticket. Instruct the voter to locate the signs matching their designated color and precinct name. (NEW: We changed White to BEIGE)
- NOTE: If the voter's ticket did NOT properly print or they lost it before receiving their ballot, print a duplicate ticket per the instructions on page 46.
  - **Important: Confirm the voter is at the correct precinct and use the ticket to legibly PRINT the Voter's name in the Numbered List of Voters in the White Binder, [O].** See page 47 for instructions.

**TIP:** You may write the voter's number from the numbered list on the ticket to keep them straight and to assist in line management.

12. Place the ticket in the **Lime Poll Pad Envelope** in front of the binder. The voter may now vote. Give the voter the correct precinct paper ballot, a pen and a privacy folder.

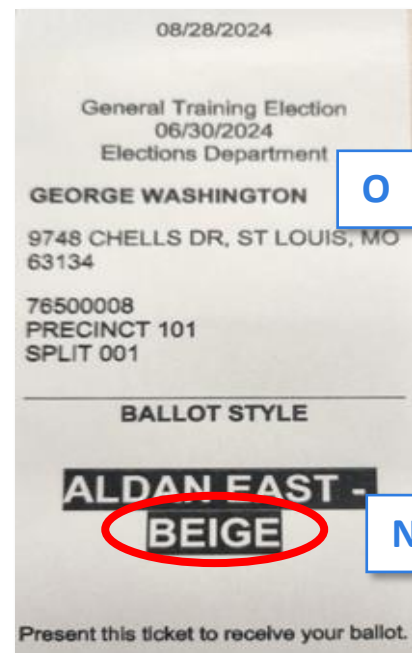

## Poll Pad: Voter Check-in Procedure (Continued)

13. Tell voters that they must individually select each candidate on the ballot. Explain how to properly mark the ballot pointing out the directions on the ballot. Then direct the voter to the privacy booths/area to manually mark their ballot.



To vote, fill in the box to the left of your choice. To vote for a candidate who is not listed, print the name in the Write-in space and fill in the box to the left. Do NOT use Write-in space for a candidate who is already listed for that office.

If you are voting in your precinct and make a mistake, ask for a new ballot.

Use only blue or black ink.

**Board of Elections**

14. After marking the ballot, the voter proceeds to the ballot scanner to cast their ballot. See page 48.

15. If the voter makes a mistake marking their ballot, they may spoil it and request a new ballot. See page 50.

Note: If any voter is unable or feels uncomfortable voting by manually marking the paper ballot, direct them to the ADA compliant Touch Writer to mark the ballot digitally. **ANY** voter may use the Touch Writer, if requested. They are not necessarily asking for assistance; they may have just forgotten their reading glasses, etc. See page 63.

<b>Acceptable</b> Inside the box	
<b>Acceptable</b> Inside the box	
<b>Acceptable</b> Inside the box	
<b>Not Recommended</b> Outside the box lines	
<b>Not Recommended</b> Outside the box lines	

## Directions to Reprint Poll Pad Ticket

- If a voter's ticket needs to be reprinted, use the **ORIGINAL** Poll Pad to pull up their record and tap **REPRINT**. Enter the password from the **Black Pouch** and tap **DONE**.

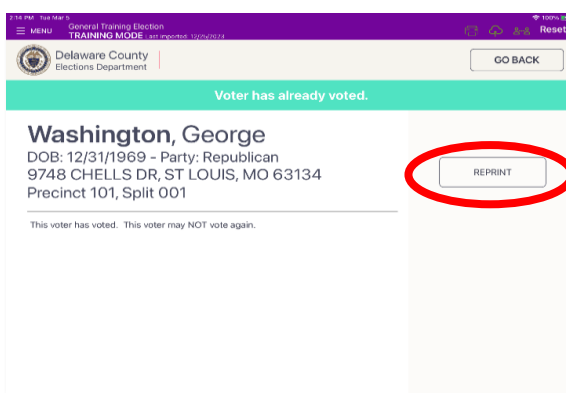

- A DUPLICATE ticket will reprint.
- **NOTE:** You may need to reprint a ticket because the printer jammed, ran out of paper, etc. Remember to always print a test receipt after "fixing" the printer or paper.

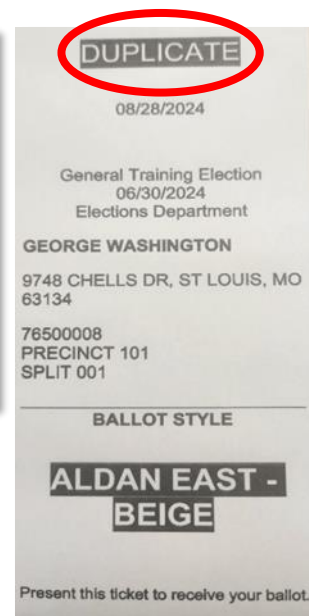

# Instructions: Numbered List of Voters

The binder contains a carbonless list with a top white page and bottom yellow page. [P] Each page set is divided by a separation page. Each page in the binder is numbered 1 to 100. The page numbers will be prefilled beginning with page 0 (zero).

- **IMPORTANT:** Before adding any names to the list, verify they are at the correct precinct and are **not** a provisional voter.
- Use the voter's ticket to announce the voter's name clearly.
- Use the voter's ticket to print last name first legibly on the list. Then place the ticket in the Lime Green Poll Pad Envelope [Q] in front of the binder. Some larger precincts may have extras or a manila envelope as well.
- If a voter's name is accidentally added to the list, boldly cross out the number and name of the voter. **DO NOT REUSE THIS LINE OR RENUMBER THE LIST.**
- **NEW TIP: You may write the number on the ticket to keep them straight and to assist in line management.**
- **IMPORTANT: Throughout the day, verify the last number on the list, minus any cross outs is equal to the number of ballots scanned on the scanner.**

For example, the last number is 308, there are 2 cross outs and 3 voters marking their ballot and the actual number of voters that checked in is 306 (308 - 2). The scanner should match 303 votes cast. Note the reason for any differences to make closing smoother.

Mark the line where you reconciled counts. You will only need to review votes after the mark.

- Poll Watchers may inspect and photograph this list. But only while supervised by a poll worker and the polling place is not busy. Poll Watcher activities should slow down or interfere with the voting process.

**Reminder: No provisional voters are included on the list. There is NOT a separate list for provisional voters.**

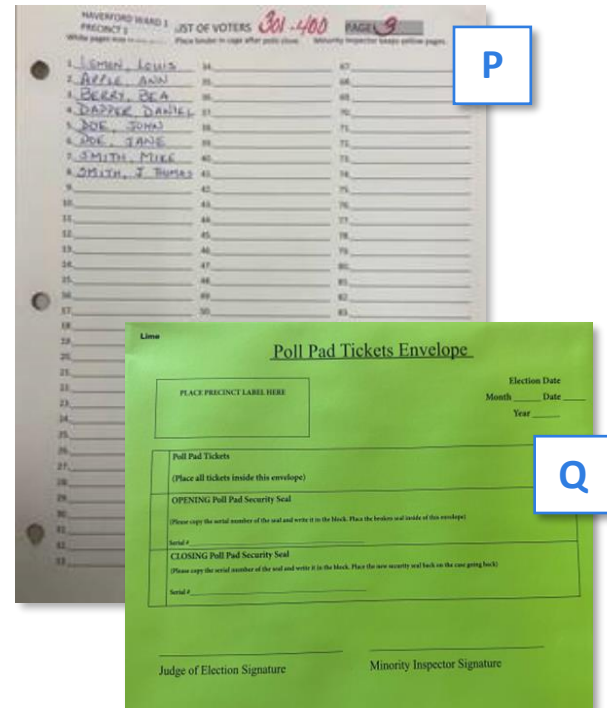

# Ballot Scanner Procedure

**RESPECT THE VOTER'S PRIVACY AT THE SCANNER. DO NOT LOOK AT THE BALLOT. NEVER TOUCH THE VOTER'S BALLOT.**

1. Instruct the voter to remove their ballot from the privacy folder, if using, and insert the ballot into the scanner.
2. Voter inserts their marked ballot into the scanner as directed by the flashing green arrows (ballots must be fed in short edge first but can otherwise be inserted in any direction). [A] ▼
3. Voter must wait for the scanner to finish processing. "Please wait" message will be displayed on screen. [B] ▼
4. When the scanner has accepted a ballot, the screen will flash the American flag and a brief message that the vote has been recorded. [C] ▼
  - Once the ballot is accepted, thank the voter, ask them to please return their pen and privacy folder, give them an "I Voted" sticker and direct the voter to the exit.
  - If the scanner rejects the ballot, it will spit back out and an error message will display. Review the message and assist the voter. See examples on the next page.
5. **Throughout the day, verify that the last number on the numbered list — minus any cross outs — equals the number of ballots scanned.**

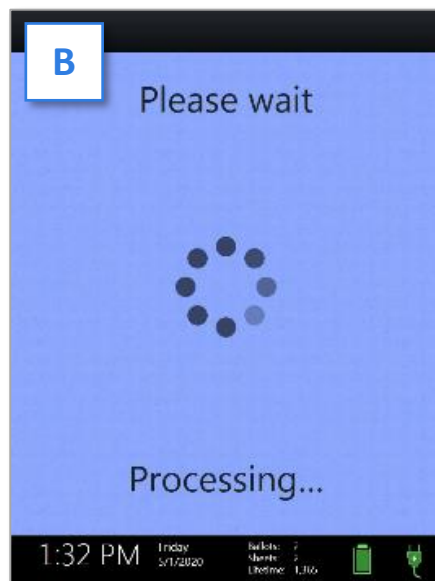

**IMPORTANT: If multiple ballots are NOT scanning properly, try using a different package of ballots. Note this on the 3 Return Sheets.**



# Scanner Messages and Voter Instructions

**PRECINCT 1-2 SCANNER WILL ONLY ACCEPT BALLOTS FROM PRECINCT 1-2.  
ALL OTHERS WILL BE REJECTED.**

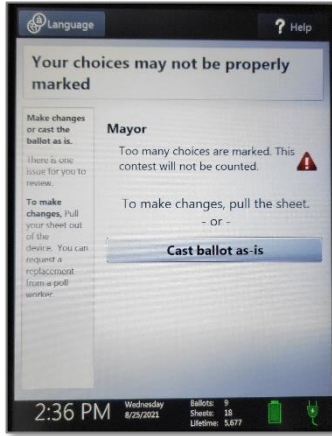

## Overvote:

- Too many choices were marked on the ballot.
- The voter has two options:
  - Spoil the ballot with a poll worker and receive a new ballot to correct the error. See page **50** for instructions.
  - Voter taps “Cast ballot as-is” on the screen. The overvoted contest will **NOT** be counted, but all other contests will be counted.

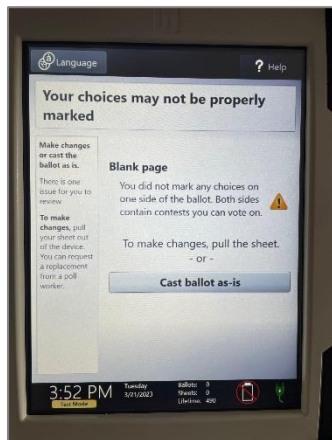

## Blank Page:

- The scanner is not reading any valid selections on all contests on one side of the ballot.
- The voter has three options:
  - Voter taps “Cast ballot as-is” on the screen.
  - Take the ballot to the voting booth to mark more choices and then return to scan ballot.
  - Spoil the ballot and vote on a new ballot.

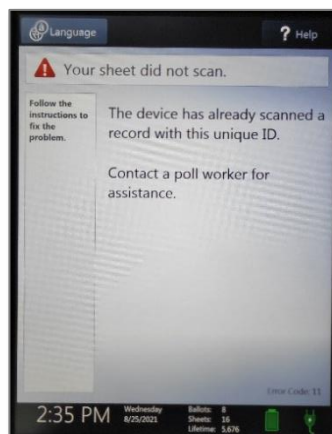

## Error Codes 6, 11 or 14:

Note: This code is listed in the lower right corner.

- Code 6: The ballot is from a different precinct than the scanner. Direct the voter to their correct precinct scanner.
- Code 11: This ballot has already been scanned. Take the voter out of line. Record the voter’s name and contact info and call Voter Services at **(610) 891-4673** and ask for a solicitor. Voters may continue to use the scanner.
- Code 14: Provisional ballots **CANNOT** be scanned. Properly file and log provisional votes per page **60**.

**Reminder:** Remember to maintain eye contact. Do NOT look at how the ballot is marked.

## How to Spoil a Ballot

**NEW:** The Spoiled/Remitted Ballot envelope has been redesigned. You will only be listing Spoiled Ballots on the log. Do NOT list remitted ballots on the log, but **STILL** put them in the envelope.

When a voter needs to spoil a ballot, do **NOT** inspect the ballot and complete the following:

- Ask the voter to write SPOILED on the ballot and to fold their ballot in half.
- Have the voter place the folded ballot in the Spoiled/Remitted Ballot Envelope. [A] ▼
- Fill out Spoiled Ballot Log (located on the back of the envelope): note the “reason spoiled” per the voter and print your name (**NOT** the voter’s name). [B] ▼
- If a regular ballot (ie not a provisional ballot) was printed on the Touch Writer, note that on the log.
- Give the voter a new ballot to complete and cast.
- **IMPORTANT: DO NOT PLACE spoiled PROVISIONAL BALLOTS in this envelope. Place them in the White Provisional Voting – Return Envelope.**

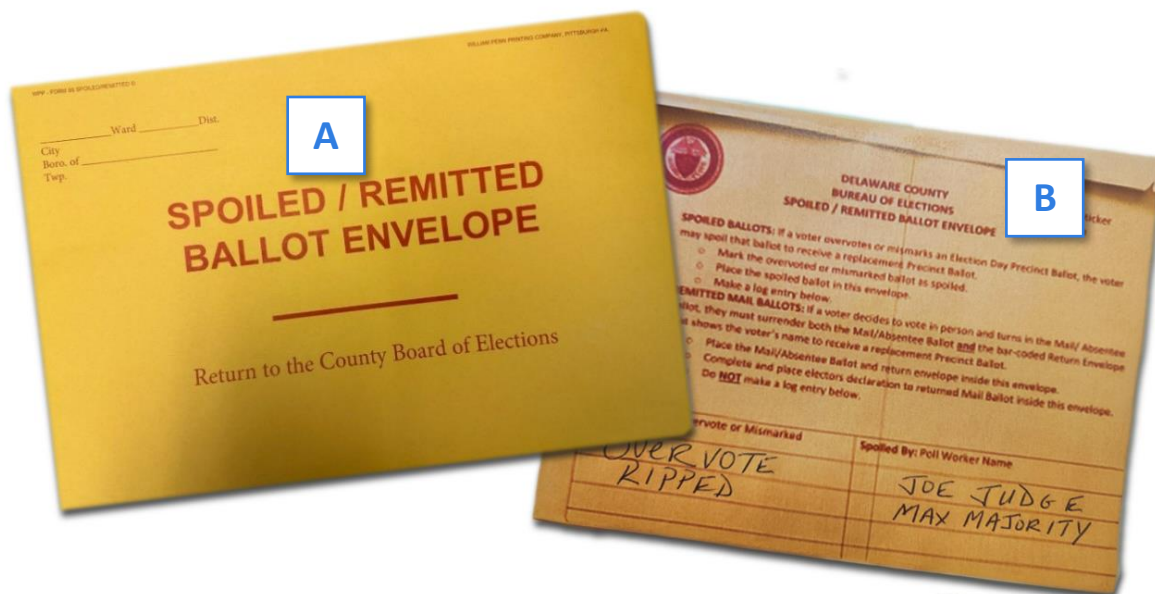

## How to Log an Abandoned Ballot

If an abandoned ballot is found, write “ABANDONED” across the ballot in large print.

Place in Spoiled/Remitted Ballot Envelope and write “abandoned” for the reason on the log.

# Messages & Situations Poll Workers May Encounter

**REMIND ALL VOTERS TO FILL OUT FORMS COMPLETELY AND LEGIBLY, WITH PROPER NAMES, ETC.**

## Address Does Not Match

- If the voter's address is not properly listed in the Poll Pad, ask the voter if they have moved. If they have moved, the voter must complete sections A and C of the yellow Affirmation of Elector Form to vote. ID is **NOT** required.
- The Poll Worker will review and sign the form. The voter will continue to proceed normally. File the form in the Used Form Envelope.
- If the voter's address has a typo or error, they should call Voter Reg to correct. If unable to contact Voter Reg, complete the yellow form and proceed normally.
- **IMPORTANT:** A voter in the Poll Pad is a registered Delco voter and is entitled to vote. Depending on the box they check off on the form – they will be removed from Delco's voter records prior to the next election

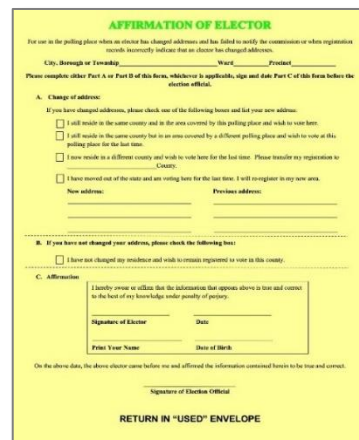

The image shows a yellow 'AFFIRMATION OF ELECTOR' form. It includes fields for City, Borough or Township, Ward, and Precinct. Section A asks if the voter has changed their address, with options for staying in the same county, moving to a different polling place, or moving to a different county. Section B asks if the voter has not changed their address. Section C is for the voter's signature and date. The form is titled 'RETURN IN "USED" ENVELOPE'.

## Inactive Voter: Affirmation Required

- Follow the directions on the Poll Pad screen. [A]
- File the completed and signed Affirmation of Elector Form in the Used Form Envelope.
- If the voter will NOT complete the Affirmation, tap the PROCESS PROVISIONALLY button, [B]. See page 60 for provisional voting procedures.

### Inactive Voter - Affirmation Required

Fillmore, Millard

DOB: 01/07/1910 - Party: Democratic

9876 CRABAPPLE AVE, ST LOUIS, MO 63134

Precinct 101, Split 001

Voter will complete the appropriate sections of the yellow Affirmation of Elector form. This voter does NOT need to show ID.

A

If the voter's address is incorrect complete section A. If the voter's address is correct, complete section B. All voters will complete section C. Once a poll worker has reviewed and signed the completed form, select Affirmation Complete and allow the voter to vote normally.

If the voter refuses to complete the form, the voter may vote provisionally. Select Process Provisionally, initial the record and this voter will work with the Judge of Elections to vote provisionally.

B

AFFIRMATION COMPLETE

PROCESS PROVISIONALLY

# Messages & Situations Poll Workers Encounter (Continued)

## Unlisted Voter

- If the voter's name cannot be found in the Poll Pad using the Advanced Options and you have verified that their name has not changed, they are not giving you a nickname or their 1<sup>st</sup> name is not an initial, pull the voter out of line.
- Together, the voter and the JOE will call Voter Reg at (610) 891-4659.
- If Voter Reg determines that the voter is at the correct precinct and properly registered, they will give you an **AUTHORIZATION NUMBER [A]** for the voter.
- The JOE will legibly complete an entry on a blank poll book page (found in the Unused Forms Envelope) based on Voter Reg's information. Ask the voter to sign the entry [B]. This voter WILL be included on the Numbered List of Voters.
- Record the Voter Number from Numbered list and initial the entry [C]. This voter will NOT sign the Poll Pad.

The diagram shows a poll book entry form with the following fields and callouts:

- Callout C:** A box containing "Voter #" and "Insp. Int".
- Fields:** Name \_\_\_\_\_, Address \_\_\_\_\_, City \_\_\_\_\_ State \_\_\_\_ Zip \_\_\_\_\_, Party \_\_\_\_\_ Date of Birth \_\_\_\_\_.
- Callout A:** A box containing "Authorization # given by Voter Reg. Clerk \_\_\_\_\_".
- Callout B:** A box containing "X" and a signature line.

**IMPORTANT:** By law, if the voter is **NOT** given an Authorization Number or cannot be found in the system by Voter Reg, the voter is **NOT** a registered voter in Delaware County and **CANNOT** vote a **regular ballot**. If the voter insists on voting allow the voter to cast a Provisional Ballot. See page 60.

# Messages & Situations Poll Workers Encounter (Continued)

## ID Required

- ID is required if a voter is voting for the first time at that precinct.
- If the voter shows one of the IDs listed on the Poll Pad screen, tap **ID CONFIRMED [A]**, and proceed to voting.
- **NEW:** The ticket will state “MUST CONFIRM ID” – initial the ticket so the poll worker manning the numbered list knows that the ID has been confirmed **[B]**.
- If unable to provide approved ID, select **UNABLE TO CONFIRM ID [C]** and the voter **MUST** vote provisionally. Remind the voter that they must present their approved ID to Voter Reg in Media to have their vote count. See page **60**.

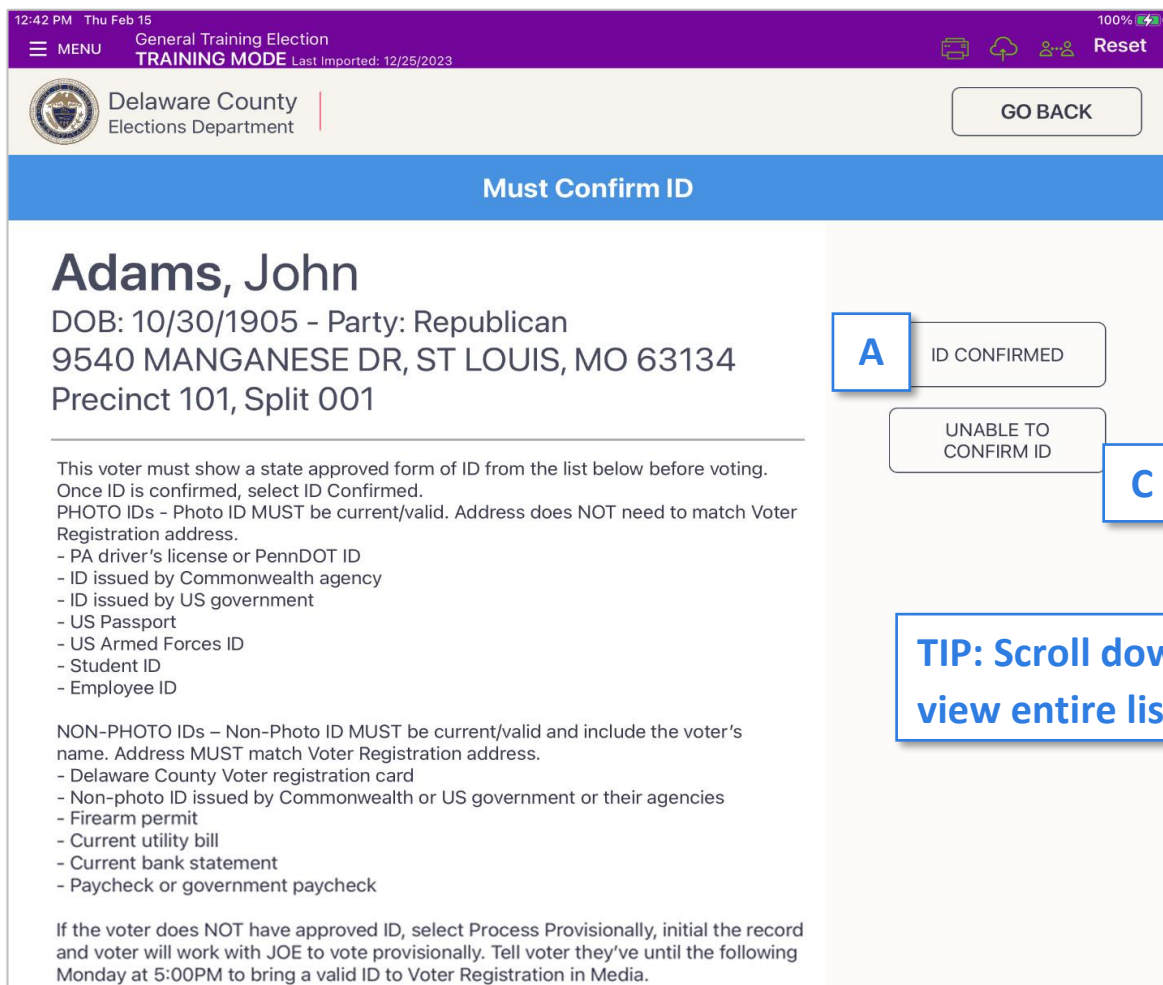
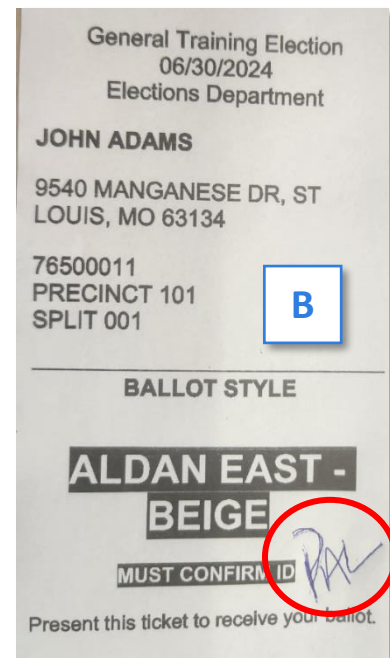

# Messages & Situations Poll Workers Encounter (Continued)

## Voter is at the Wrong Location

- If a voter is at the wrong location [A] follow the directions on the voter's record. [B]
- Strongly encourage the voter to vote in their correct precinct. Remind them all contests may **NOT** count in the wrong precinct and that voting provisionally is a time intensive process. If they opt to go to their correct polling place, give the voter their polling place ticket [C].

**NOTE:** This is the ONLY instance where a Poll Pad ticket is permitted to leave the precinct.

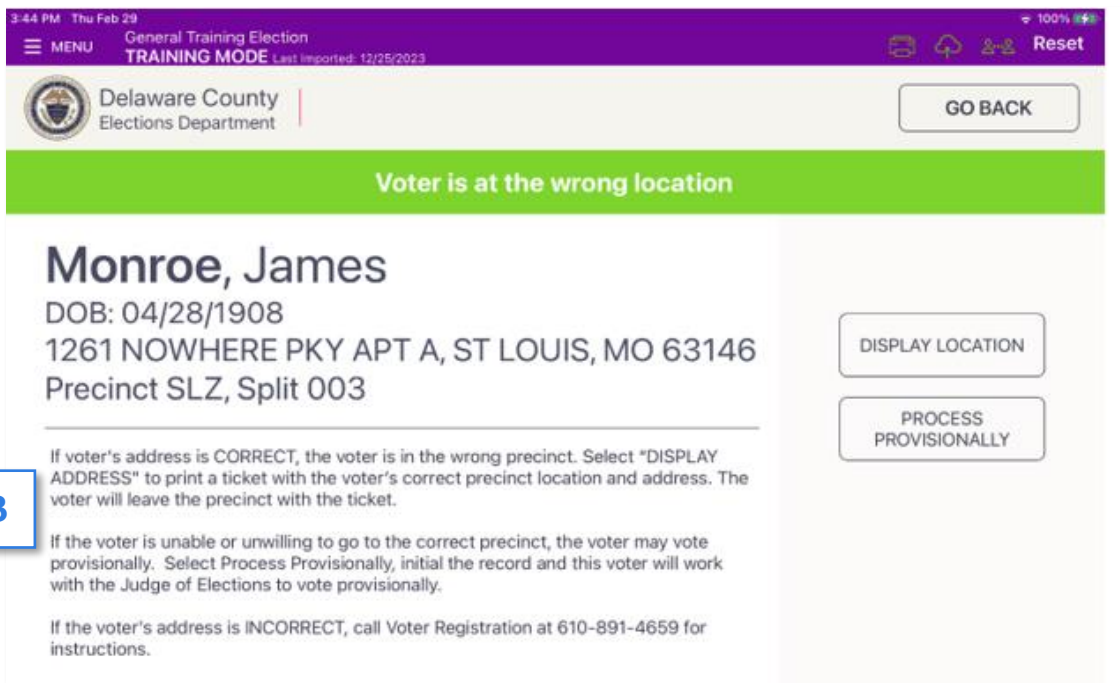
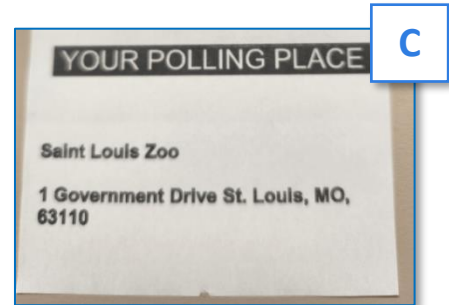
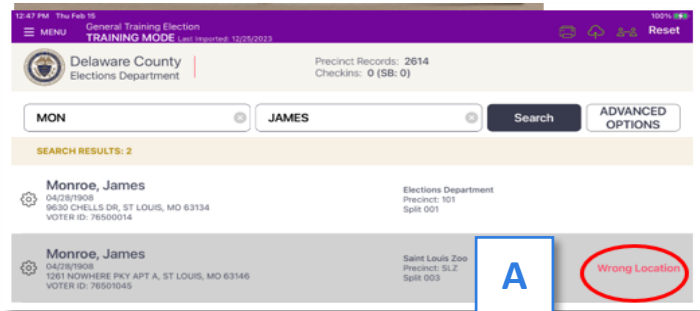

- If the voter will not or cannot go the correct precinct, they may vote provisionally. See page 60 for instructions.

# Messages & Situations Poll Workers Encounter (Continued)

## Voter Requires Assistance

- See page 94 for more information to respectfully work with voters with specific needs.
- When a voter asks for assistance and their record has a “Previous Assistance Requested” banner, [A] follow the instructions on the screen. They do **NOT** fill out the pink sheet.

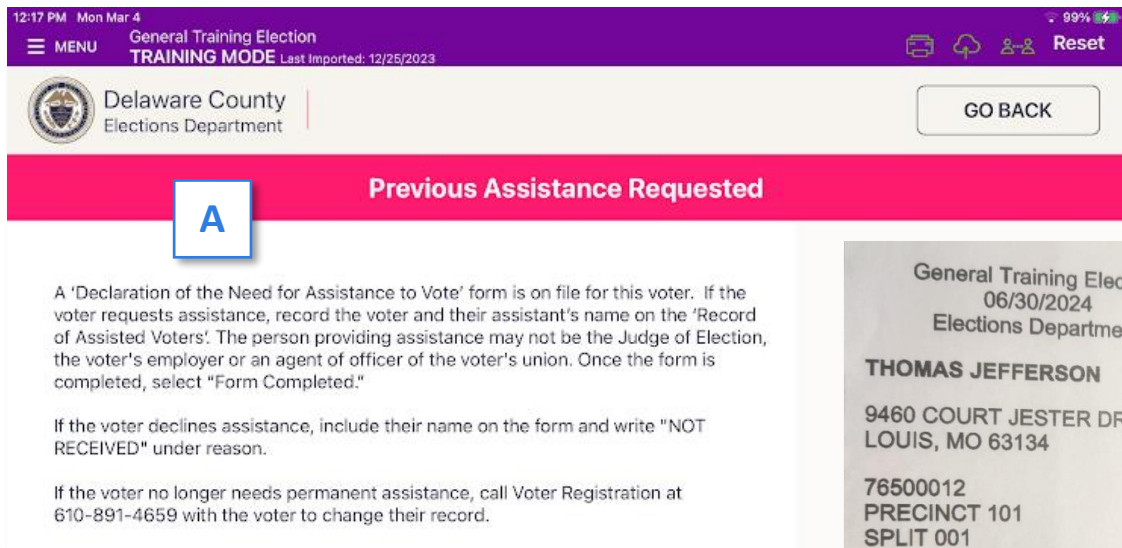

- If the voter’s record does not have the banner, ask the voter to fill out a pink Declaration of the Need of Assistance to Vote form. The form [B] must be witnessed and signed by the person providing help and the JOE. Placed it in the Used Forms Envelope. The assistor cannot be the JOE, their employer or their union agent/officer.
- Every voter receiving assistance **OR** with the “Previous Assistance Requested” banner must be included on white Record of Assisted Voters. [C] **NEW:** Use the 2-letter code on the Poll Pad ticket [D] to complete the reason.
- NOTE:** Explaining the voting process to a voter, lending reading glasses, setting up the Touch Writer for use, etc. is not offering assistance and does not need to be recorded.

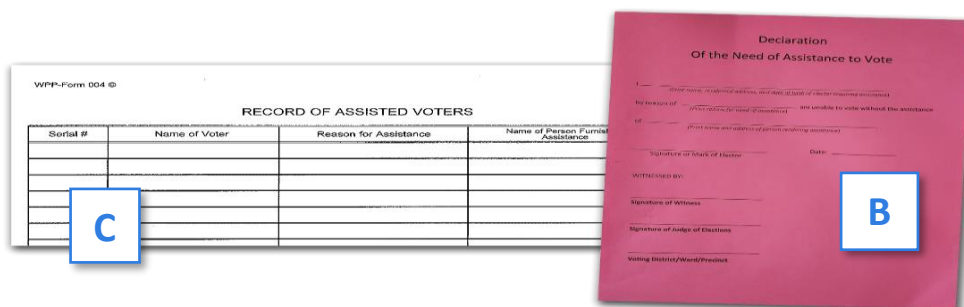
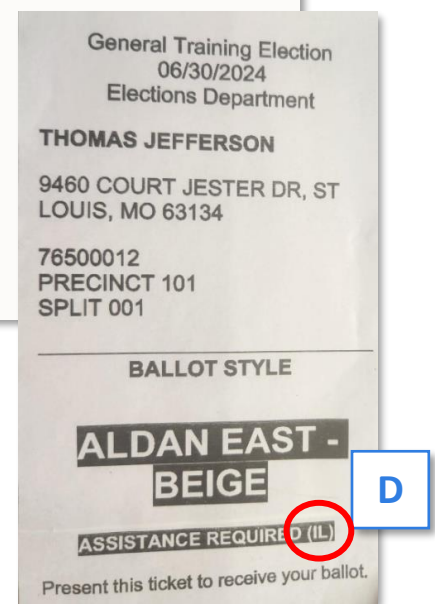

## Messages & Situations Poll Workers Encounter (Continued)

### Return Absentee or Mail-In Ballot or Vote Provisionally

A voter that was issued an absentee/mail-in ballot that has not been recorded as returned by the county and wants to vote in-person has 2 choices:

- Return BOTH the ballot AND the Purple Official Ballot Return Envelope to vote a regular ballot in-person. See next page.
- Or vote provisionally if they cannot return BOTH the ballot and the Purple Official Ballot Return Envelope. See page 60.
- In either case, remove the voter from the line to work with the JOE to resolve. Use the flowchart below to assist with the decision.

### Returning Ballot or Voting Provisionally Flowchart

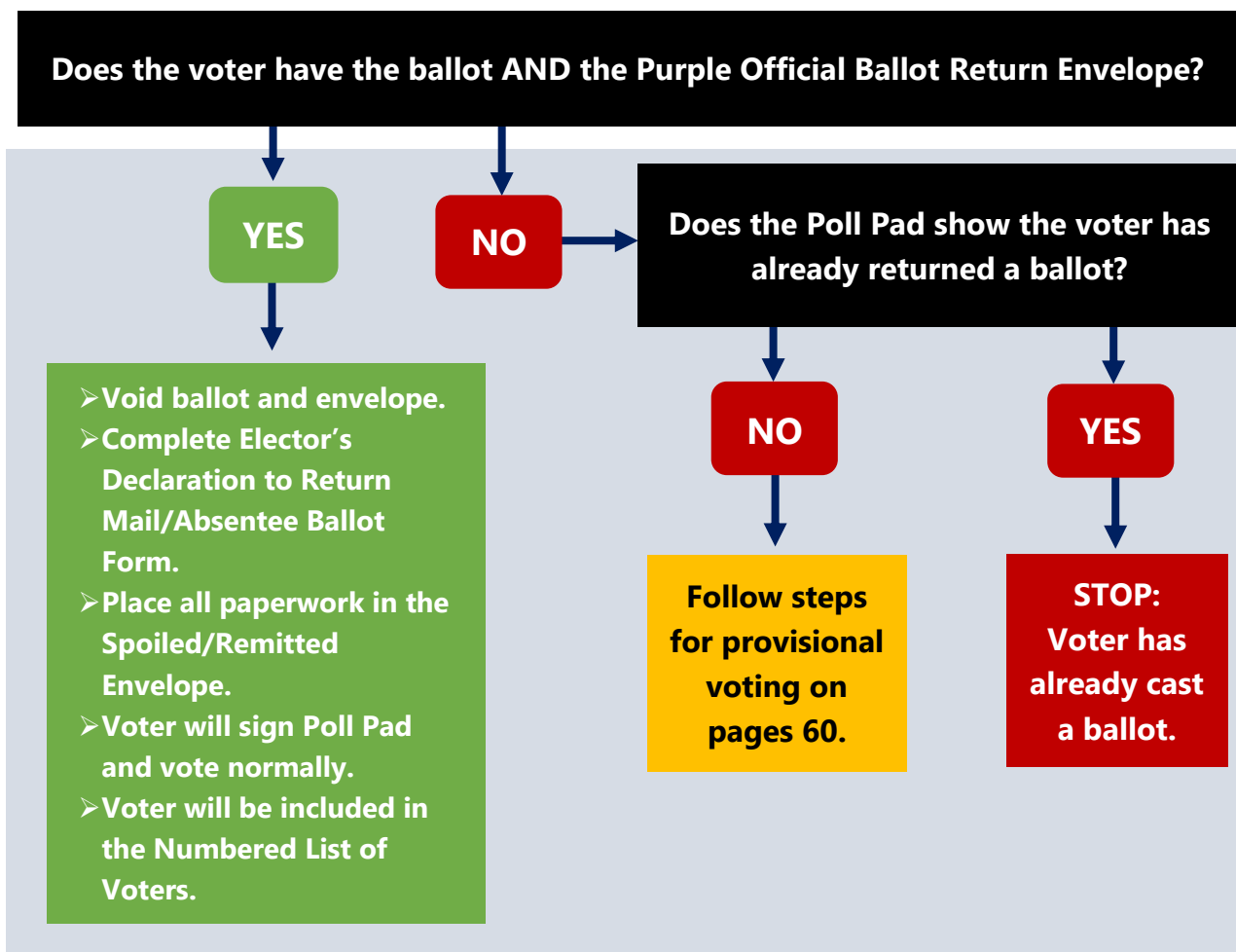



# How to Return a Mail-in/Absentee Ballot

A voter who returns their mail ballot AND their Official Ballot Return Envelope with the purple stripe will receive a replacement normal ballot and vote in the precinct. Complete the following steps:

1. Remove the voter from the check-in line to work directly with the JOE.
2. The Secrecy Envelope is **NOT** required. If sealed, verify the ballot is inside the envelope while respecting the voter's privacy.
3. Once the onscreen directions are completed, take the voter back to the check-in table and select **BALLOT/ENVELOPE REMITTED [A]** and the voter will vote normally.

**Delaware County Elections Department**

**Absentee/Mail-In Ballot Requested**

**Roosevelt, Franklin**  
 DOB: 10/12/1922 - Party: Republican  
 9790 CHELLS DR, ST LOUIS, MO 63134  
 Precinct 101, Split 001

**A** **BALLOT/ENVELOPE REMITTED**

**PROCESS PROVISIONALLY**

This voter has been issued an Absentee/Mail-In Ballot. Voters who requested these ballots are NOT eligible to vote a regular ballot UNLESS they remit BOTH the ballot and the Ballot Return Envelope with the purple stripe.

If the voter would like to vote, the Judge of Election must:

- Have the voter sign the Elector's Declaration to Return Mail/Absentee Ballot, **[B]**
- Review the form and sign off,
- Write VOID on the Absentee/Mail-In Ballot and the Ballot Return Envelope with the purple stripe, **[C]**
- Place all the above in the Spoiled/Remitted Envelope and **[D]**
- Select Ballot/Envelope Remitted and allow the voter to vote a regular ballot.

If the voter does NOT have their ballot or their Ballot Return Envelope with the purple stripe, the voter may vote provisionally. Select Process Provisionally, initial the record and this voter will work with the Judge of Elections to vote provisionally.

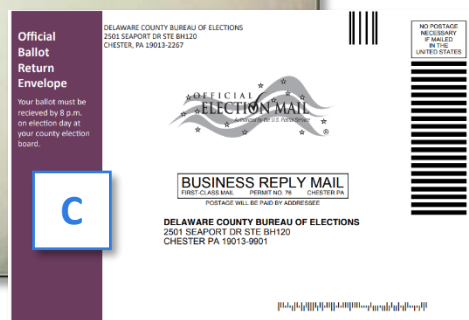

**NEW:** Follow the same directions if the Ballot Return Envelope says **"REPLACEMENT"** in red. (A replacement is issued when a voter makes a mistake on the envelope with the purple stripe, such as failing to sign it.)

**Elector's Declaration to Return Mail Ballot** DC2023-REMIT

I hereby declare that I am a qualified registered elector who has obtained an absentee ballot or mail-in ballot. I further declare that I have not cast my absentee ballot or my mail-in ballot, and that instead I remitted my absentee ballot or mail-in ballot to the judge of election at the polling place to be spoiled and therefore request that my absentee ballot or mail-in ballot be voided and I be permitted to vote a regular Election Day ballot. I make this declaration subject to the penalties of 19 PA C.S. 4904 (related to unsworn falsification to authorities).

\_\_\_\_\_/\_\_\_\_\_/202\_\_\_\_  
 Today's Date

\_\_\_\_\_  
 Voter, Sign Here

\_\_\_\_\_  
 Voter's Printed name

\_\_\_\_\_  
 Voter's address

\_\_\_\_\_  
 Judge of Election, Sign Here

\_\_\_\_\_  
 Judge of Election - Printed name

**B**

JUDGE OF ELECTION: Place completed form in Spoiled/Remitted Ballot Envelopes.

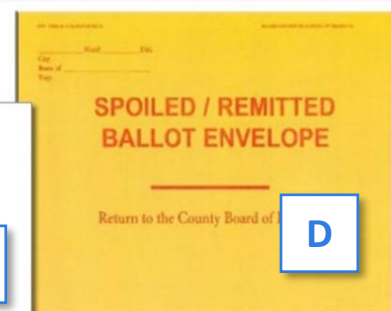

## Absentee/Mail-In – Ballot Cast/Not Eligible

**This voter must NOT cast a normal ballot.**

**EXCEPTION:** If the voter received a notice-and-cure letter, call or email from the County, they must be processed provisionally. Notice-and-cure means a problem with the Ballot Return Envelope was noticed and needs to be corrected. See page 60.

12:46 PM Thu Feb 15  
General Training Election  
MENU TRAINING MODE Last Imported: 12/25/2023 100% [Battery Icon] Reset

Delaware County  
Elections Department

GO BACK

**Absentee/Mail-In Received**

**Van Buren, Martin**  
DOB: 12/05/1902 - Party: Democratic  
9704 CHELLS DR, ST LOUIS, MO 63134  
Precinct 101, Split 001

PROCESS PROVISIONALLY

This voter's Absentee/Mail-In ballot has been received by Delaware County's Board of Elections. If the voter insists on voting or received a notice-and-cure letter or email from the County, they must be processed provisionally. Select Process Provisionally, initial the record and this voter will work with the Judge of Elections to vote provisionally.

## Wrong Voter is Checked In

Assume John Smith Sr. signs John Smith Jr.'s record and it is accepted.

If the mistake is caught while John Smith Sr. is still in the polling place, do the following:

- Bring John Smith Sr. back to the Poll Pad and properly check him in on his correct record. He will then proceed to vote normally.
- The poll worker will collect the John Smith Jr. ticket from John Smith Sr. Write a note on the ticket and place it in the **LEMON BOE envelope**.
- Call Voter Reg and inform them about the incident.
- Alert all poll workers manning the Poll Pads of the situation with John Jr.
- When John Jr. attempts to sign in – he cannot. His record will state he has voted. Remove him from the line to work with the JOE and call Voter Reg.

If the mistake is NOT caught until John Jr. attempts to sign in, do the following:

- Pull John Jr. out of line and have him vote provisionally. See page 60.
- The JOE will write on the White Provisional Ballot Envelope “Another voter signed the record” as the reason why the John Jr. is voting provisionally.

## Voters May Cast a Provisional Ballot If:

**Note: The County Board of Elections will verify that no voter votes twice.**

- Voter was issued but did not return their Absentee/Mail-In ballot **AND** the Purple Official Ballot Return Envelope.
- Voter's name does not appear in the Poll Pad and their registration status cannot be determined or Voter Registration cannot be contacted within a reasonable amount of time to verify a person's eligibility.
- A court order has been issued to the voter.
- If a voter is at the wrong precinct, and the voter is unable or unwilling to go to the correct precinct. Only certain contests will count and if in the wrong county, ballot will not count. **NEW:** JOE must handwrite "In Wrong Precinct" as reason.
- A voter's eligibility by an election official is challenged for cause and challenge cannot be resolved by the JOE.
- Poll Pad message is "ID Required" and the voter is unable to show approved ID (see page 53). The voter will have until the following Monday at 5:00PM to bring valid ID to Media's Delaware County Voter Registration office to have their vote counted.
- Voter received a notice-and-cure letter or email from the County.
- Voter's record was incorrectly signed by another voter. **REMEMBER** to handwrite "Voter's record was signed by the wrong voter" as reason.

**PROVISIONAL VOTERS NEVER SIGN THE POLL PAD AND ARE NEVER INCLUDED ON NUMBERED LIST OF VOTERS.**

**IMPORTANT and NEW:** The BOE added yellow highlighted boxes where signatures are necessary! Do NOT allow a voter to be disenfranchised because you did not sign the envelope and/or ask the voter to fully complete their section.

# Provisional Ballot Instructions

- A poll worker will initial the voter's record [A] on the Poll Pad and place the printed Poll Pad ticket [B] in the **Lime Poll Pad envelope**. NOTE: The Voter will NOT be able to sign the Poll Pad. [C]
- The JOE gives the voter the **White Provisional Ballot Envelope**. Direct voter to fill out sections 1 – **Voter Information [D]** and 2 – **Voter Affidavit for Provisional Ballot [E]** on the envelope.
  - Note: Section 2 requests the address where the voter is registered to vote.
  - If their current address is different from their registered address, have the voter fill out section 3, **Current Address where the Voter Lives [F]**, on the envelope before receiving a ballot.
- Have voter sign Section 2 of the envelope where indicated [G].
- **All Provisional voters will generate their ballots on the Touch Writer. Ask voter if they want to mark their ballot on the Touch Writer or on a paper ballot and set up the Touch Writer accordingly. The Touch Writer will print a Provisional Ballot stub [H] each time a Provisional Ballot is printed. Place the stub in the White Provisional Voting – RETURN Envelope. See page 64 for Touch Writer instructions.**
- Instruct voter to place the marked ballot in the **Green Secrecy Envelope** then **SEAL IT**. If unsealed, the provisional ballot will not be counted at the county level.
- Direct voter to place the sealed **Green Secrecy Envelope** inside the **White Provisional Ballot Envelope** and seal it.
- Instruct voter to sign and date with 11/5/24 or November 5, 2024 on Section 4 – **Voter Signature [I]** – on the **White Provisional Ballot Envelope**.
- The JOE will inspect the **White Provisional Ballot Envelope** to ensure the voter has signed it in sections 2 and 4 and properly completed the envelope.
- The JOE will select the Reason for Ballot from the list where indicated on the bottom section of the **White Provisional Ballot Envelope**. [J]
- Both the JOE and Minority Inspector will sign and date the **White Provisional Ballot Envelope**. [K]
- The JOE must then place a bar-coded receipt sticker in the space provided on the envelope marked **AFFIX BALLOT ID NUMBER HERE**. [L] Give voter their portion of the receipt, which allows the voter to track their provisional ballot's status.
- Place sealed **White Provisional Ballot Envelope** and the **signed Provisional Ballot Stub** from the Touch Writer in the larger **White Provisional Voting – RETURN Envelope**.
- Log and file all provisional ballots according to the instructions on page 86 to properly seal and secure these ballots for return to the County at the end of the night.

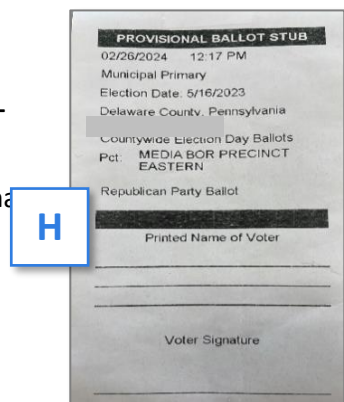
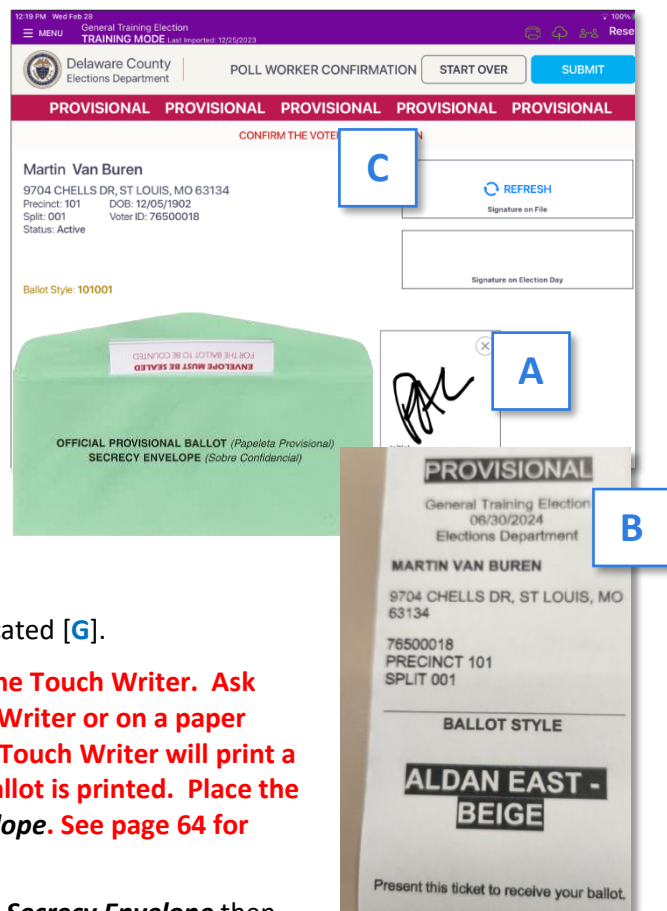

# Provisional Ballot Instructions (Continued)

**Provisional Ballot/Boleta electoral provisional**

**1. Voter Information** (Voter must complete this section in front of election officials BEFORE receiving ballot.) **D**

**VOTER NAME** \_\_\_\_\_  
 Print Voter Name  
**VOTER DATE OF BIRTH** \_\_\_\_\_  
 Date of Birth  
**VOTER PHONE NUMBER** \_\_\_\_\_  
 Phone  
**VOTER EMAIL ADDRESS** \_\_\_\_\_  
 Email

**2. Voter Affidavit for Provisional Ballot** (Voter must complete and sign in front of election officials BEFORE receiving ballot.)

Please print the address where voter is registered:

**VOTER STREET ADDRESS** \_\_\_\_\_ **E**  
 Address  
**VOTER CITY / ZIP CODE** \_\_\_\_\_  
 City Zip code  
**VOTER TWP/MUNI / COUNTY (DELAWARE)** \_\_\_\_\_  
 Voter Municipality Voter County

I do solemnly swear that my name and date of birth are as I have listed above, and at the time I was issued and resided at the address I have provided above, in the Commonwealth of Delaware, and that this is the only ballot that I have cast in this election. **G**

**VOTER MUST SIGN**

Voter Signature \_\_\_\_\_

**3. Current Address where the Voter Lives** (Voter must complete this section in front of election officials BEFORE receiving ballot if address is different than section 2.) **F**

**VOTER FILLS OUT ONLY IF VOTER ADDRESS HAS CHANGED**

Address (street) \_\_\_\_\_  
 City Zip code

**4. Voter Signature** (Voter must sign in front of election official AFTER receiving and voting ballot.)

I declare, under penalty of law, that I am a properly registered voter in the election district indicated in my affidavit, and that I am eligible to vote in this election in this election district.

Voter, sign or mark here

**VOTER MUST SIGN** \_\_\_\_\_ **I**

**VOTER PRINTS NAME** \_\_\_\_\_  
 Voter, Print name here  
**VOTER PRINTS TODAY'S DATE** \_\_\_\_\_  
 Date (MM/DD/YYYY)

**FILL OUT ALL SECTIONS, WITH SIGNATURES WHERE INDICATED**

**Reason for Ballot** (For election officials only)

Check all boxes that apply: **Judge of Election will select a box.**

Voter's name not on list  Party (Primary only) **J**  
 Court order (voter)  
 Identification not supplied  Which Party Ballot is enclosed?  
 Voter (voting hours)  Voter was issued Mail-in ballot **K**  
 Eligibility is challenged  Voter was issued Absentee ballot

**JUDGE OF ELECTION MUST SIGN & DATE**  
 Signature of the Judge of Election \_\_\_\_\_ Date \_\_\_\_\_

**MINORITY INSPECTOR MUST SIGN & DATE**  
 Signature of the Minority Inspector \_\_\_\_\_ Date \_\_\_\_\_

**This section is for election officials only**

This space is reserved for voter registration verification by county board of elections. **L**

Provisional ballot barcode receipt sticker goes here Affix Ballot ID Number Here.

9" x 12" Open End

## Guidance for Challenges

Persons are presumed to be bona fide, qualified electors and must be allowed to vote if their names appear in the County's Poll Pad of registered voters. However, there may be cases when another voter, an election officer or a credentialed poll watcher challenges the right of a registered elector to vote. Below is guidance to help the Judges of Election understand how to proceed.

1. Challenges are limited to:

- The identity of the elector (voter),
- The residence of the elector (voter),
- An alleged violation in signing the voter's certificate, or
- An alleged violation of laws that ban bribery.

## Guidance for Challenges (Continued)

- Challenges may **NOT** be made to the legitimacy of the registration itself. By law, such challenges must be filed with the Voter Registration Commission.
- Challenges must be made in good faith. Challenges **CANNOT** be made routinely, frivolously or with no good-faith basis. The JOE must remove from the polling place anyone making challenges routinely, frivolously or with no good-faith basis.
- If the elector (voter) establishes his or her identity or residence **to the satisfaction of the JOE**, the elector must be allowed to sign the Poll Pad and receive a regular ballot.
- When to use the “CHALLENGES” form to issue a ballot to a challenged elector:**

- When a JOE cannot decide, in good faith, the identity or residence of a challenged elector (voter), the challenged elector may complete the “CHALLENGES ELECTOR’S AFFIDAVIT” form, and also have another qualified elector (voter) complete the “SUPPORTING AFFIDAVIT” section on that same form.
- The CHALLENGES form is **NOT** needed for challenges where the Judge was satisfied with the Elector’s identity or residence in item (4) above.

**When the CHALLENGES form has been completed with the Elector’s Affidavit and the Supporting Affidavit, the Elector (voter) then is processed normally and receives a regular ballot, NOT a provisional ballot.**

The image shows a form titled "CHALLENGES ELECTOR'S AFFIDAVIT" with a "SUPPORTING AFFIDAVIT" section. The form is for the Commonwealth of Pennsylvania and is used to challenge an elector's identity or residence. It includes fields for the elector's name, address, and the date of the challenge. The form also includes a section for the supporting affidavit, where another qualified elector can provide evidence to support the challenge. The form is printed on white paper with black text and is titled "CHALLENGES ELECTOR'S AFFIDAVIT" in bold letters. The supporting affidavit section is titled "SUPPORTING AFFIDAVIT" in bold letters. The form is numbered "WVP - Form 3" in the top left corner. The form is printed by "Wilson Print Printing Company, Pittsburgh, Pa." in the top right corner. The form is titled "CHALLENGES ELECTOR'S AFFIDAVIT" in bold letters. The supporting affidavit section is titled "SUPPORTING AFFIDAVIT" in bold letters. The form is numbered "WVP - Form 3" in the top left corner. The form is printed by "Wilson Print Printing Company, Pittsburgh, Pa." in the top right corner.

**IMPORTANT:** Any person who intentionally refuses to permit a person to vote, when that person is entitled to vote under the law, is committing a crime under the Pennsylvania Election Code and the Federal Voting Rights Act.

**IMPORTANT:** A provisional ballot is needed only when:

- the JOE agrees that a challenge is well-founded, **AND**,
- the elector (voter) cannot submit a completed CHALLENGES form.

# Voting with the Touch Writer

## Overview: Touch Writer and Verity Access

The Touch Writer is an accessible ballot marking device. On the Touch Writer, poll workers will activate a ballot, and then allow the voter to begin voting. When they are finished voting, the voter will print the marked ballot. The voter will cast their ballot using the scanner to be processed centrally. If using the Touch Writer to process a Provisional Ballot, the voter can choose to mark their choices on the machine or print a blank Provisional Ballot and mark it manually. Using the Touch Writer does not necessarily mean that a voter requires assistance.

## About Verity Access

Verity Access is intended for voters that cannot, or prefer not to, use the touchscreen. Verity Access includes two connection ports: the left connection port for headphones, and the right connection port for any dual-switch input device (such as tactile switches or sip-and-puff devices). With Verity Access, a voter can:

- Navigate through a ballot with the **Move** wheel
- Make selections on a ballot with the **Select** button
- Activate help text using the **Help** button

## Installing Headphones and Tactile Switches

1. Lift the Verity Access from its cradle.
2. Plug the supplied or the voter's headphones into the headphone port on the top left of the Verity Access. [A] ▼
3. Plug the tactile switches, sip-and-puff, or any other dual-switch input device into the port on the top right of the Verity Access. [B] ▼



## Poll Workers Activate the Ballot

1. When the device is ready to be used for marking ballots, the **Ready for Use** screen will display.
2. Press and hold your finger on the **Ready for Use** button to continue (or press the **Blue Poll Worker Button** on the back of the Touch Writer). [A] ▼
3. Enter the **Poll Worker Code** from the **Black Pouch** and select **Accept**. [B] ▼
4. **To activate a provisional ballot, select Mark as provisional [C] ▼**
5. Confirm selections, then select **Yes, activate this ballot**. [D] ▼

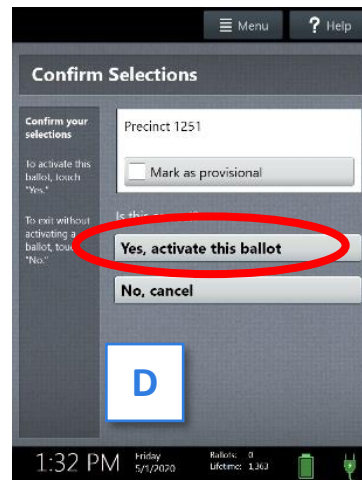
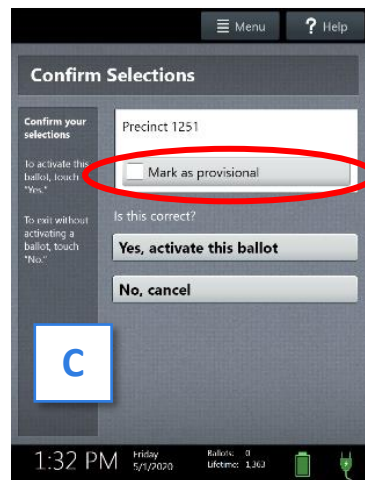
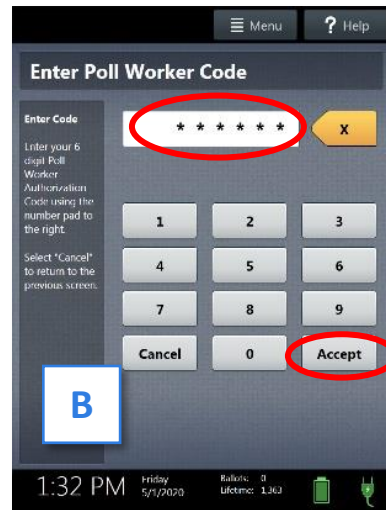
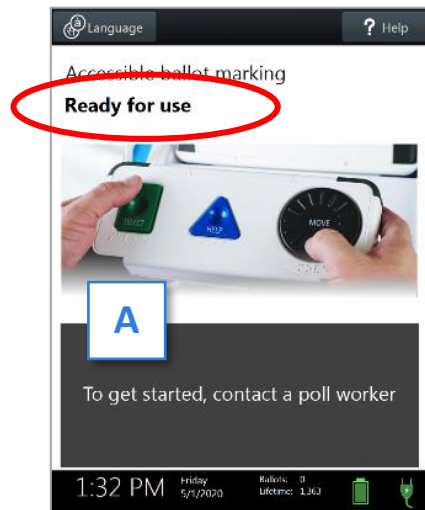



## Marking Ballots with Touch Writer

Once a poll worker has activated a regular or provisional ballot:

1. The voter selects **“To get started, touch here”** (or turns the Move Wheel on Verity Access clockwise). [A] ▼
  - If multiple languages are available, a “get started” button will appear in multiple languages. The voter selects the button with their preferred language.
  - The language selected applies to both the device instructions and the ballot.
  - The language settings can be changed at any time by accessing the language menu.
2. The voter chooses if they would like to use the Verity Access accessibility features. [B] ▼
  - If the voter chooses **Yes, help me change the settings**, they will proceed to the next step.
  - If the voter chooses **No, skip straight to voting**, they will be taken to the About Your Ballot screen.
3. The voter selects whether to use the screen, audio, or both to complete their ballot, and then adjusts their audio and/or screen settings. [C] ▼
  - If the voter chooses to use both the screen and audio, they will then be walked through the audio settings and screen settings before proceeding. The voter selects **OK, it sounds good/OK, it looks good** in the bottom right to proceed.
  - If the voter chooses to use the screen only and turn off the audio, they will be asked to confirm before proceeding, by selecting **Yes, turn it off**. The voter will then be walked through the screen settings before proceeding. The voter selects **OK, it looks good** in the bottom right to proceed.
  - If the voter chooses to use the audio only, they will be asked to confirm before proceeding, by selecting **Yes, turn it off**. The voter will proceed through their ballot using the Access device with headphones. The voter can **select Touch here to enable the screen** to turn the screen display on at any time.

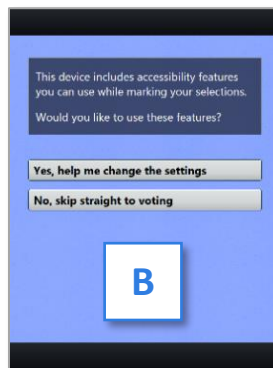
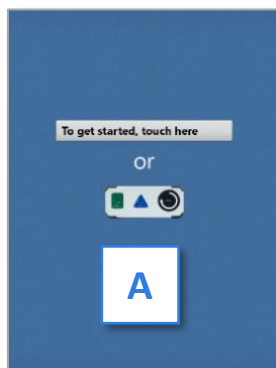

## Marking Ballots with Touch Writer (Continued)

4. The voter is presented with three screens of instructions that orient them to the Touch Writer device. The voter can select **Next** to view each instructional page or select **Skip Instructions** to go to their ballot. [D] ▼
  - On the last page of instructions, the voter selects Start in the bottom right to begin marking their ballot.
  - The Language (if applicable), Audio, and Screen settings and the **Help** button are also available.
5. The voter can start voting (by selecting **Begin Voting**), learn how to use the ballot, or view a list of contests on the ballot. [E] ▼
6. The voter makes their ballot choices using either the touchscreen or the **Move wheel** or **Select** button on Verity Access. [F] ▼
  - A selected choice will display a green box with check mark to the left of the choice.
  - The voter can review ballot choices by selecting **Review your choices**.
  - The **Next** or **Skip** button advances to the next contest on the ballot after reviewing all candidates (voter must scroll to bottom of contest)
7. If a Provisional voter chooses to print a blank Provisional ballot to manually mark, keep choosing **Next** or **Skip**. [G] ▼

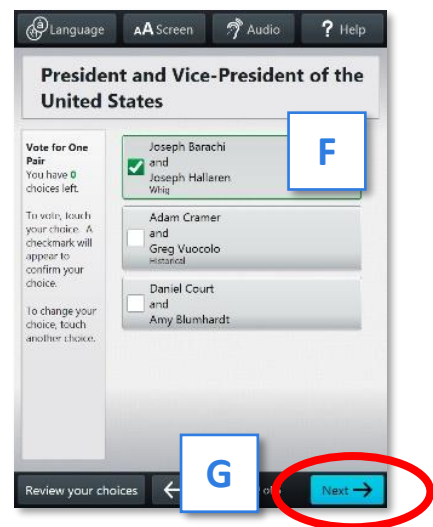
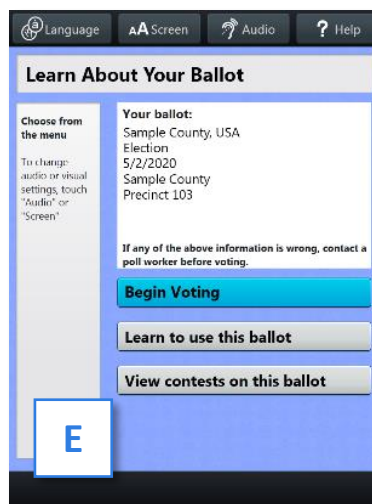
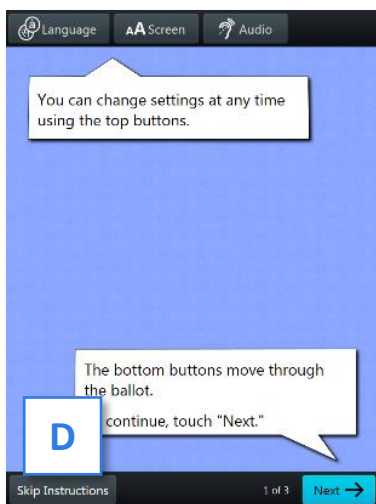

## Marking Ballots with Touch Writer (Continued)

8. When the voter has reached the end of the ballot, the **Review your ballot** screen appears.
  - The voter can select a specific contest to return to that contest, or select **Return to ballot** to go to the last contest visited.
9. After reviewing and confirming their choices, the voter selects **Print** to print the ballot. [H] ▼
10. The voter selects **Yes, print my ballot**. [I] ▼
11. The voter retrieves the printed ballot from the printer next to the Touch Writer. [J] ▼
  - The voter will take their printed regular ballot to the scanner to cast their ballot.
  - Provisional ballots are **NEVER** accepted by the scanner.
  - A Provisional Ballot Stub prints with each Provisional Ballot [K]. Instruct the voter to print their name and sign the stub. Once the ballot is marked, the voter returns to the JOE to complete necessary paperwork and file the stub, per page 60.

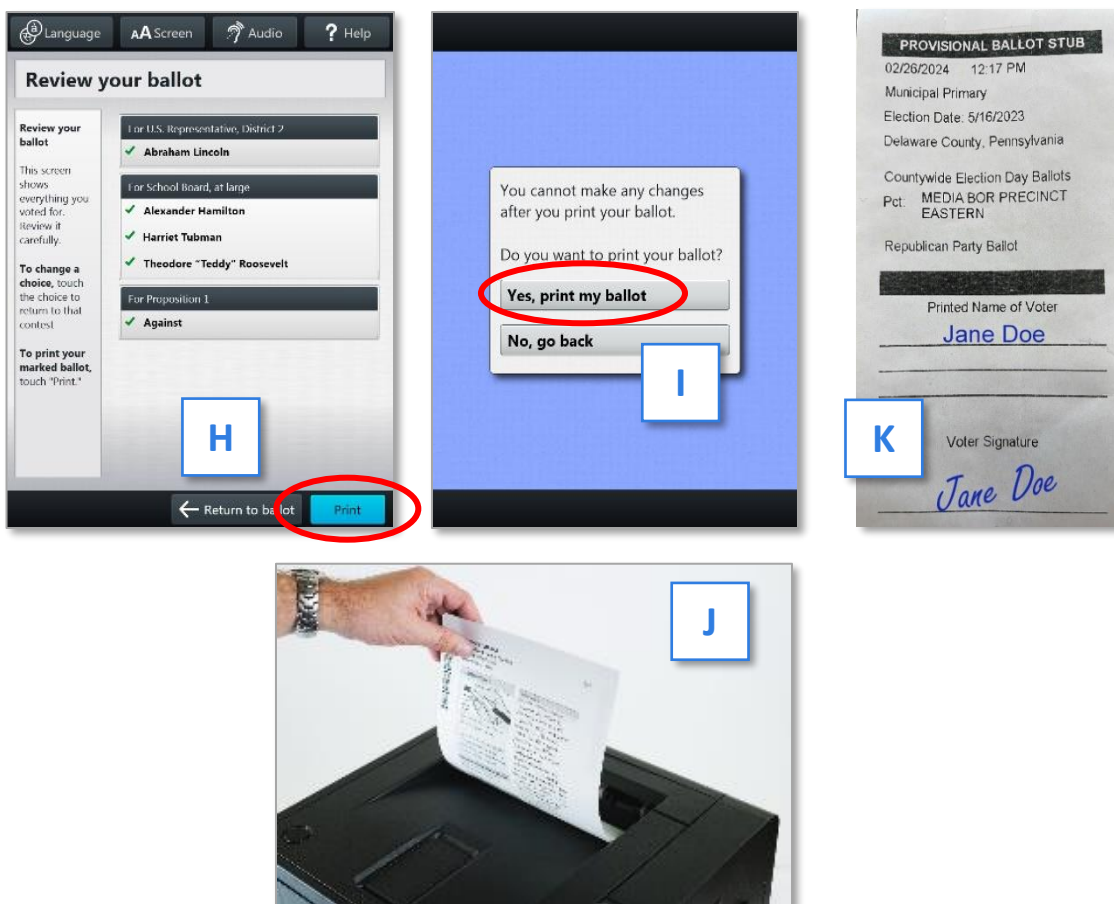

## Making Write-in Choices

To vote for a write-in candidate on the ballot (if applicable):

1. On the page for that contest, the voter selects **To enter a write-in, touch here**.
2. The voter types the name of the desired write-in, using the touchscreen or Verity Access, and then selects **Accept**.
3. The voter's write-in choice will appear with a green box with check mark to its left, along with the write-in candidate name that the voter typed.

Note: If a voter attempts to deselect a marked write-in choice, they will be asked to confirm before proceeding.

## Substitutions

In a contest with more than one valid choice (e.g., 'vote for one, two or three'): If the voter has already selected the allowed number of choices, and then selects an additional choice, the Touch Writer will indicate which previous choice is being changed, and which new selection is being added.

## Touch Writer Help and Features

Each Touch Writer is equipped with context-specific help text and settings that can be accessed from the touchscreen or using Verity Access. To exit help or settings screens and resume voting, select **Exit Help** or **Return to ballot** on the bottom right.

- If multiple languages are available, a **Language** button [A] ▼ is located at the top left of the screen. Voters can select this button to change the language of the instructions and ballot.
- Voters can select the **Screen** button [B] ▼ to change the screen settings (contrast and text size), or to turn the screen off (if using headphones only).
- Voters can select the **Audio** button [C] ▼ to change the audio settings (volume and speed) for the headphones.
- The **Help** button [D] ▼ is at the top right of the screen. Voters can select this button to see help text for the voting step currently underway.



## Troubleshooting

If there is a problem with the Touch Writer, follow the error instructions on the screen (if applicable), and/or contact the Voter Machine Warehouse for assistance.

Note: If a visually impaired voter is stuck, remind them to move the wheel clockwise to activate the voice menu.

## Spoiling a Ballot on Touch Writer

- Press the **Blue Poll Worker Button** on the back of the Touch Writer.
- Enter the Poll Worker Code from the **Black Pouch** and select **Accept**.
- Select **Spoil current ballot**.
- Select **Yes, spoil the ballot**.
- Select **OK**. **There is no need to file paperwork for spoiled ballots not printed.**

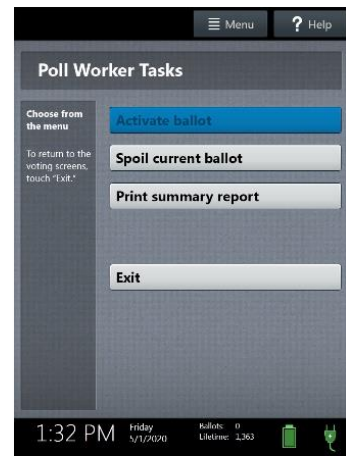

## Spoiling Printed Touch Writer Paper Ballots

- To spoil a regular ballot that has already been printed from Touch Writer ask the voter to write SPOILED on it, fold it and place it in the SPOILED/REMITTED Ballot Envelope. Complete the Spoiled Ballot Log noting it was printed on the Touch Writer. See page 50
- A spoiled Touch Writer Provisional Ballot should be placed in the **white Provisional Voting – Return Envelope**.
- In either case, see page 64 to produce another ballot for the voter.

---

PAGE INTENTIONALLY LEFT BLANK  
USE PAGE FOR NOTES



# CLOSING THE POLLS

## CLOSING ACCURATELY AND EFFICIENTLY

- ❖ Polls must stay open until all voters in line at 8:00PM have voted.
- ❖ DO NOT close the polls before 8:00PM. Once polls have closed, they cannot be reopened.
- ❖ Poll watchers and candidates are permitted to remain in the precinct during closing but must not disrupt the poll workers.
- ❖ All supplies marked **Return to County** on pages 84-87 **must** be returned to the Media Government Center immediately after completing the closing process. **WARNING!** If you are missing these items, you will be required to return to your precinct to collect those items. Review pages 84-87 to avoid having to make two trips!

Call the Voting Machine Warehouse at (610) 874-8780 or the Poll Worker Hotline at (484) 460-3750 with any problems.

# Task List: Closing the Precinct and Polls

**JOE: Use this list to distribute closing tasks**

NAME	CLOSING TASK
NAME	Fill out and sign the Affidavit of Voter Identification Form and file the form in the <b>Lemon Bureau of Elections Envelope</b> . <b>TIP: ANY morning workers must complete the Affidavit before leaving.</b>
NAME	Open the Ballot Box and verify there are no unscanned Ballots in the Emergency Slot Bag. If there are, scan them first (see page 92) and then proceed.
NAME	Remove Ballot Bag from Ballot Box. <b>Do NOT add anything to the bag!</b> The Ballot Bag only contains cast ballots! Seal with <b>Green Security Seal</b> located in the <b>Black Pouch</b> . Record the seal number on Certificate 3 of all 3 Return Sheets. Close Ballot Box.
NAME	Close Polls on the Scanner. Follow the step-by-step procedures beginning on page 74.
NAME	Close Polls on the Touch Writer. Follow the step-by-step procedures starting on page 76.
NAME	Secure the Scanner and Touch Writer vDrives in the <b>White vDrive Security Return Envelope</b> and place in the top clear sleeve of <b>Gray Ballot Bag</b> . Instructions on page 77.
NAME	Close and seal the Poll Pad. Follow the step-by-step procedures beginning on page 78.
NAME	Count unused ballots. Do not unwrap to count them. Record the number of unused ballots on the boxes and Certificate 3 on all 3 Return Sheets.
NAME	Unused ballot inventory: <ul style="list-style-type: none"> <li>▪ Seal cardboard ballot boxes w/tape, all workers will sign over the tape.</li> <li>▪ Write the number of unused ballots on the label.</li> <li>▪ Return <b>ALL</b> cardboard ballot boxes to the equipment cage, including empty boxes.</li> </ul>
NAME	Fold up voting booths, ballot box, table and all other equipment used.
NAME	Pack Equipment Cage according to photo in plastic sleeve including the metal sign stand and all laminated signs. Note any equipment issues on the Manifest Sheet. <b>Do NOT Seal yet!</b>
NAME	Separate only the <b>USED</b> Numbered List of Voters pages in the binder. Record the total number of voters (subtract the total number of crossed off lines) on all Return Sheets – Certificate 2. <ul style="list-style-type: none"> <li>▪ All white pages, separation pages and unused yellow pages will remain in binder and be returned on the top shelf of equipment cage.</li> <li>▪ Used yellow pages will be placed in the <b>Pink Minority Inspector Envelope</b>.</li> </ul>
NAME	Complete the <b>White Provisional Voting - Return Envelope</b> (See page 86) and place in the large Ziploc bag along with all unused Provisional Ballots supplies. Place the sealed Ziploc bag in the <b>Green Tote</b> .
NAME	The <b>sealed baby-blue bag</b> containing the poll books and supplemental pages remains in the <b>Green Tote</b> .
NAME	<b>NEW:</b> Place the Spoiled/Remitted Envelope on the top shelf of the equipment cage.



NAME	CLOSING TASK
NAME	Complete and sign all 3 Return Sheets. <ul style="list-style-type: none"> <li>▪ Return Sheet Certificate 1 – Filled out at poll opening – page 38.</li> <li>▪ Return Sheet Certificate 2 – Poll Closing – Voter Tally – page 80.</li> <li>▪ Return Sheet Certificate 3 – Poll Closing – Paper Ballot Audit – page 82.</li> </ul>
NAME	Place one completed Return Sheet in each of the following locations: <ul style="list-style-type: none"> <li>▪ Post the <b>White Return Sheet</b> in precinct – visible from outer door or window.</li> <li>▪ File the <b>Aqua Return Sheet</b> in the <b>Aqua Machine Warehouse Envelope</b>.</li> <li>▪ File the <b>Pink Return Sheet</b> in the <b>Pink Minority Inspector Envelope</b>.</li> </ul>
NAME	Complete and verify the contents of the <b>Pink Minority Inspector Envelope</b> , see page 87. JOE and Minority Inspector must sign the <b>Pink Minority Inspector Envelope</b> . Minority Inspector will take sealed envelope home and maintain securely for two years.
NAME	Complete and verify the contents of the <b>Aqua Machine Warehouse Envelope</b> , see page 87. JOE and Minority Inspector must sign the <b>Aqua Machine Warehouse Envelope</b> . Return the <b>Aqua Machine Warehouse Envelope</b> on the top shelf of equipment cage.
NAME	Verify that the <b>Lemon Pay Sheet</b> has been filled out and signed by all Poll Workers. Double check that the JOE has signed at the bottom of the sheet. Place it in the <b>Lemon Bureau of Elections Envelope</b> .
NAME	Confirm the <b>Lemon Bureau of Elections Envelope</b> contains all forms listed on the envelope, per page 86. Include any notes to the Hotline and/or the Bureau of Elections. JOE and Minority Inspector must both sign the <b>Lemon Bureau of Elections Envelope</b> . Seal and place in the <b>Green Tote</b> .
NAME	Take down all posters, notices, and sample ballots. Place in Posting Notices Envelope. Place in the <b>White Supply Box</b> .
NAME	Pack the <b>White Supply Box</b> according to the inventory list on page 85. Place the fully packed Supply Box and <b>Black Pouch</b> with codes in the <b>Green Tote</b> .
NAME	Collect pens, “I Voted” stickers, tape and any other loose election supplies and place them in the plastic supply bag. Place plastic bag in the <b>Green Tote</b> .
NAME	Before sealing the <b>Green Tote</b> confirm it is properly packed per page 85.
NAME	Return precinct to its original state or as discussed with the site’s manager.
NAME	Determine who is dropping off the sealed the <b>Green Tote</b> and the sealed <b>Gray Ballot Bag</b> with the <b>White vDrive Security Return Envelope</b> placed in the top plastic sleeve to the County in Media. <b>Reminder: Whoever is returning the election materials to Media must wear the lanyard with keys. The Affidavit is ONLY needed if not a poll worker. Call Hotline at 484-460-3750 for Affidavit information.</b>
NAME	Seal the <b>Green Tote</b> with the <b>White Security Seal</b> in the <b>Black Pouch</b> and record the seal number on Certificate 3 on all 3 Return Sheets.
NAME	Before sealing the equipment cage with the <b>Red Security Seal</b> from the <b>Blue Bag</b> , take one last look around the precinct to verify there are no stray items. <b>DO AT END</b> .
NAME	Turn off lights, lock doors, and see that all Poll Workers are safely escorted to their cars.

# Closing the Polls: Scanner

**IMPORTANT: Do not close the polls until 8:00PM or until ALL voters in line at 8:00PM have voted. Once the Polls have been closed, they cannot be re-opened.**

1. Check the emergency ballot bag in the ballot box for any ballots prior to shutting down the machine. Scan these ballots with a bipartisan team. See page 92 for complete Emergency Ballot procedures.
2. Remove the **Gray Ballot Bag** from the Ballot Box. Do NOT put anything else in the **Gray Ballot Bag**! It is for scanned ballots ONLY!
3. Seal Ballot Bag with **Green Security Seal** from the **Black Pouch** and record the **Green Security Seal** number on Certificate 3.
4. Press the **Blue Poll Worker Button** on the back of the Scanner. Be careful! Do **NOT** press the **Red Power Button**. **NEW: If you accidentally turn off the scanner, you will be required to restart the scanner and properly Close the Polls. Turning off the scanner does not close the polls.** Call the Equipment Warehouse or the Poll Worker Hotline immediately if you do accidentally power off the scanner.
5. Select **Close Polls**. [A] ▼
6. Select **Yes, Close the polls**. [B] ▼
7. Enter the Close Polls Code (found in **Black Pouch**) and select **Accept**. [C] ▼ The Close Polls Report including a Tally Report prints automatically. Then 4 Tally Reports print automatically.

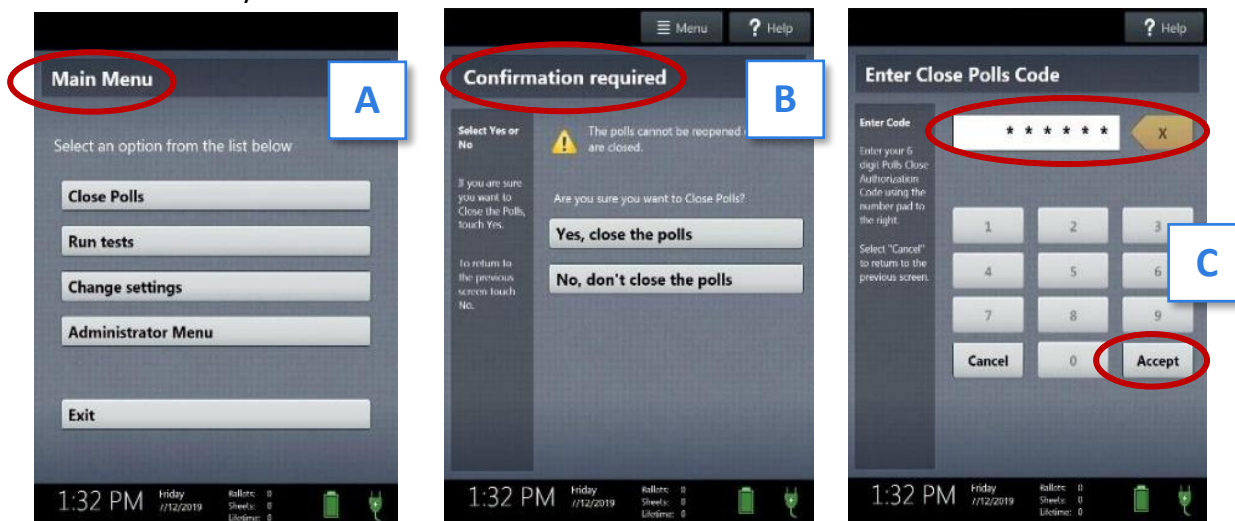

**THE POLLS ARE NOW CLOSED. THEY CAN NOT BE RE-OPENED!**

## Closing the Polls: Scanner (Continued)

8. Record the Ballot Counter and Lifetime Counter numbers from the Scanner's Close Polls Report on Certificate 2 on all 3 Return Sheets. All present poll workers will sign the Close Polls report.
9. Separate the automatically printed Tally reports and have all present poll workers sign **ALL** Tally reports. **TIP:** You may label the tally reports in the upper right corner to help keep track of them.
10. Select **Print Write-In Report**. **NOTE:** Machine report tapes will be long - some may be over 6'. If additional roll of report tape is needed, see Machine tape replacement instructions on page 93.
11. After printing reports, wait at least 10 seconds then press the **Red Power Button** on the back of the scanner to power it off. Call the Poll Worker Hotline or the Machine Warehouse if the scanner does not power off.
12. Once the scanner is completely powered down and showing a black screen, follow instructions on page 77 to remove the vDrive and reseal the vDrive compartment.
13. Disconnect the power cord by grasping the cord at the base of the black connector molding where it connects to the scanner and slide back the sleeve. This will unlock the connection so the cord may be removed. Place the cords in the storage compartment.
14. Unlock and unlatch the tablet from the cradle. When storing, make sure to lock tablet in with the blue key and pull blue latch down to secure it in place.
15. Close the Scanner case, unlatch it from the Ballot Box and place it in the cage.



## Scanner Report Filing Instructions

- The signed Closed Polls report with the Tally report will be taped to the **Aqua Return Sheet** being placed in the **Aqua Machine Warehouse Envelope**.
- Signed Tally and Write-In reports will be taped to the **White Return Sheet** posted at the precinct.
- A signed Tally report will be taped to the **Pink Return Sheet** to be placed in the **Pink Minority Inspector Envelope**.
- One signed Tally report each will go to a Republican Party Representative and a Democratic Party Representative. If a party representative is not present at poll closing, write their party on the Tally report, and **(NEW)** place it in the **Aqua Machine Warehouse Envelope**.
- **TIP:** You are NOT required to print extra reports for watchers or all candidates – they may take photos of the reports printed.

# Closing the Polls: Touch Writer

1. Press the **Blue Poll Worker Button** on the back of the Touch Writer. **Be careful! Do NOT press the Red Power Button.** (See photo on pg. 74) Call the **Equipment Warehouse** or the **Poll Worker Hotline** immediately if you do accidentally power off the Touch Writer.
2. Select **Menu** in the upper right corner of screen. [A] ▶
3. Select **Close Polls**.
4. Select **Yes, Close the polls**.
5. Enter the Close Polls Code (found in **Black Pouch**) and select **Accept**. The Close Polls report prints automatically.

**THE POLLS ARE NOW CLOSED.  
THEY CANNOT BE RE-OPENED.**

6. Record the Lifetime Counter number from the Touch Writer Close Polls Report on Certificate 2 on all 3 Return Sheets.
7. Record the total of ballots printed in the precinct less provisional ballots and the total of all Provisional Ballots on Certificate 3 on all 3 Return Sheets.
8. Select **Print Ballot Count**. Print 2 of these reports. [B] ▶
9. All present poll workers must sign ALL machine tape reports and file as instructed:
  - The Close Polls Report will go in the **Aqua Machine Warehouse Envelope**.
  - One Ballot Count Report each will go in the **Pink Minority Inspector Envelope** and **(NEW)** the **White Provisional Voting – Return Envelope**.
10. After printing reports, wait **at least 10 seconds**, then press the **Red Power Button** on the back of the Touch Writer to power it off.
11. Once the Touch Writer is completely powered down and showing a black screen, follow instructions on the next page to remove the vDrive.
12. Disconnect the power cord by grasping the cord at the base of the black connector molding where it connects to the Touch Writer and slide back the sleeve. This will unlock the connection so the cord may be removed. Place the cords in the storage compartment.
13. Attach **Blue Security Seal** from the blue bag over the printer port on the back of the Touch Writer. Record the seal number on Certificate 2 on all 3 Return Sheets.
14. Unlock and unlatch the tablet from the cradle. When storing, make sure to lock tablet in with the key and pull blue latch down to secure it in place.
15. Close the Touch Writer case, unlatch it from the table and place it in the cage.

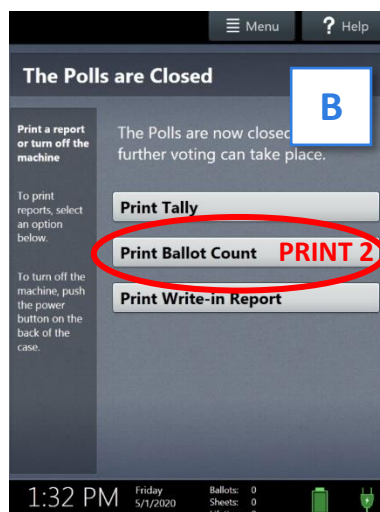
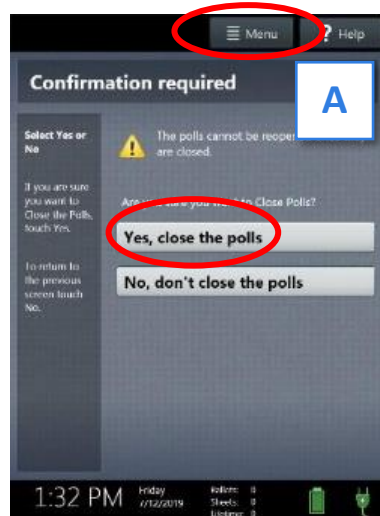

# Closing the Polls: vDrive Removal and Return

Complete the following steps on the scanner and Touch Writer once both devices are powered down:

1. Break the security seal on the vDrive compartment. [A] ▼
2. Deposit both security seals in the **Aqua Machine Warehouse Envelope**.
3. Unlock and open the vDrive compartment with the red key from **Black Pouch**. [B] ▼
4. Remove the vDrive from the USB slot. [C] ▼
5. Place both vDrives in the **White vDrive Security Return Envelope** and seal.
6. Add **Blue Security Seals** (from the **Blue Bag** in cage) to the vDrive compartments for both the Scanner and Touch Writer before closing equipment. [D] ▼
7. Record the new seal numbers on Certificate 2 on all 3 Return Sheets.

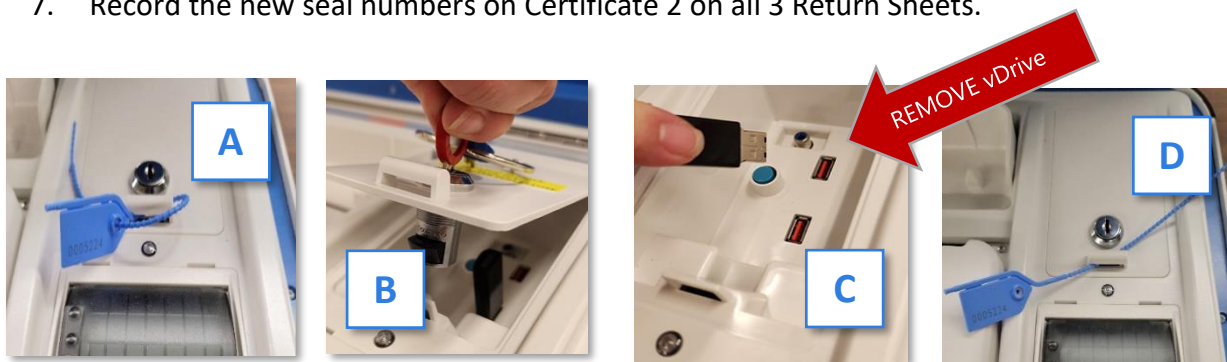

**IMPORTANT! Do not use security seals on equipment handles.**

8. The JOE AND ALL PRESENT POLL WORKERS must sign seal over the flap! [E]

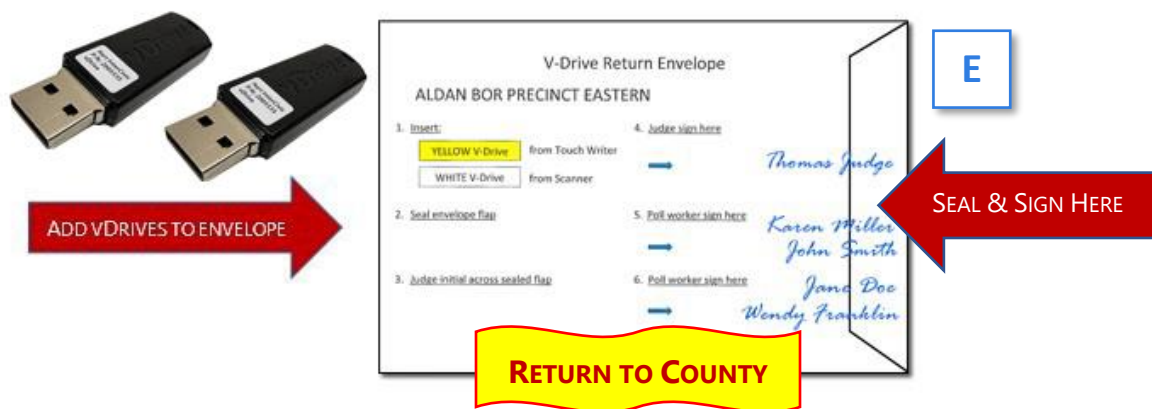

**IMPORTANT: Place the signed and sealed vDrive envelope in the top clear sleeve of the gray ballot bag.**

# Closing the Polls: Packing up the Poll Pad

1. Unplug the green cord from the Poll Pad. [A]
2. **NEW:** Hold the POWER Button on the top left edge and the round HOME Button on the right side of the screen together for several seconds. The screen will turn black, the white Apple logo will appear and then disappear. **Let go of the buttons as soon as the Apple logo disappears.** The screen will go black and stay black. If the white Apple logo appears, try again after the Poll Pad reboots. [B] Try twice and if the Poll Pad does not turn off place in case.
3. Verify the case's luggage tag matches the sticker on the on the printer cover. [C]
4. Unplug the power cord from the outlet. Separate the power adapter from the power cord. Place the power cord in the case. [D]

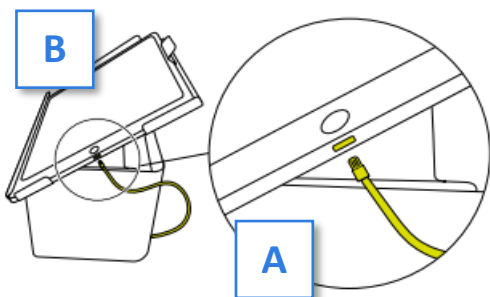

5. Lift the Poll Pad firmly with 2 hands and gently place it in the case. [E] Tuck in the green cord and the adapter into their slot. [F]

6. Pack any remaining accessories including all styluses [G], cleaning cloth and the rapid wall charger (if present) and printer paper [H].

7. Close and seal the case with the **Lime Security Seal** found in the Poll Pad case.
8. Record the seal number on the **Lime Poll Pad Tickets Envelope** in the **White Binder**.
9. Place the Poll Pad/s in the Equipment Cage. **Do NOT return the Poll Pad/s to Media!**
10. Place the extension cord, the power strip and green tape, if present, in the cage.

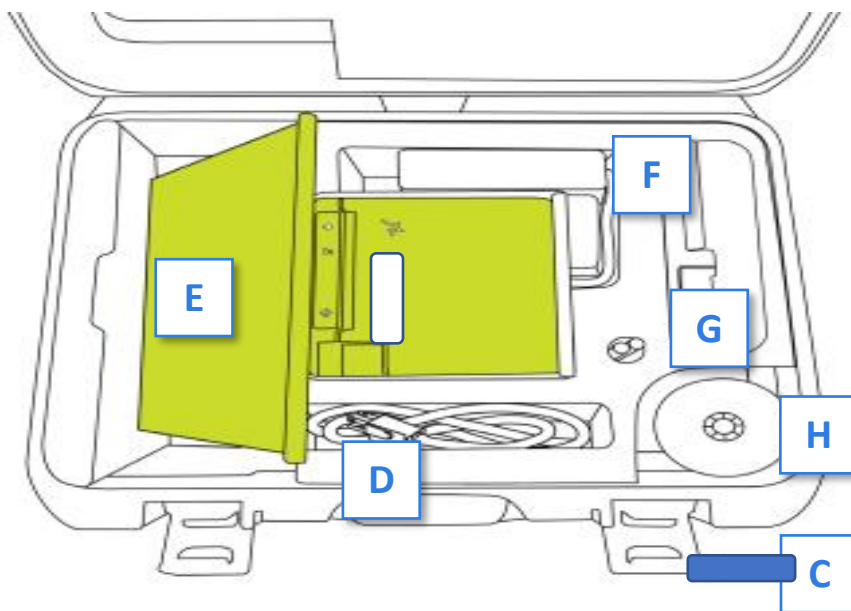

# Sample Return Sheet

**Delaware County - Return Sheet**  
**General Election**  
**Tuesday, November 5, 2024**

**RIDLEY WARD 2 - 3**

Place completed and signed sheet in Pink Minority Inspector envelope.

Attach Tally Report Here

**POLL OPENING - CERTIFICATE 1**  
*Before opening the polls, record these numbers from the equipment and the reports. Verify all "Zero & Open Polls Reports" show zero votes cast. Call warehouse if incorrect.*

ELECTION EQUIPMENT	BLUE Seal Number vDrive Compartment <i>Unseal at Poll Closing</i>	Serial Number from Open Polls Report	Lifetime Counter from Open Polls Report
Ballot Scanner			
Touch Writer			

RED Seal # on Cage: \_\_\_\_\_ BLUE Seal # Back of Touch Writer: \_\_\_\_\_

**POLL CLOSING - CERTIFICATE 2**  
*After closing the polls, record these numbers from the equipment, reports and numbered list of voters.*

ELECTION EQUIPMENT	BLUE Seal Number vDrive Compartment <i>Seal when Repacking</i>	BALLOT COUNTER from Close Polls Report	Lifetime Counter from Close Polls Report
Ballot Scanner			
Touch Writer			

RED Seal # on Cage: \_\_\_\_\_ BLUE Seal # Back of Touch Writer: \_\_\_\_\_

**TOTAL # VOTERS:**      *Record the last number displaying a voter from the numbered list, minus any lines that were crossed out and unused.*

**PAPER BALLOT AUDIT - CERTIFICATE 3**  
*Fill out at poll closing with all paper ballot numbers. Record seal numbers used for the live ballots.*

	BALLOTS
Total Ballots received in cage	
Regular Ballots printed on Touch Writer	
Total Provisional Ballots including Spoiled from the Provisional Voting Return Envelope	
Total of Unused Ballots <i>(Count remaining at poll close)</i>	
Total Spoiled Regular Ballots <i>(Refer to spoiled/remitted ballot env.)</i>	

**You must record these security seal numbers. Print numbers clearly.**

Scanner Gray Tote Bag Seal # <i>Contains all scanned paper ballots</i>	
Green Tote Bag Seal # <i>Contains all cast provisional votes</i>	

*Notes on discrepancy or other important items:*

*We, the undersigned Election Officials, certify that we have followed all procedures prescribed by law, before, during and after the Election.*

POSITION	PRINTED NAME	SIGNATURE
Judge of Elections		
Majority Inspector		
Minority Inspector		
Machine Operator		
Clerk		

Attach Machine Tape

SEE PAGE 38

SEE PAGE 80

SEE PAGE 82

PRINT WORKER NAMES & SIGN HERE

IMPORTANT NOTE:

"Total # Voters: From Numbered list" number should match the "BALLOT COUNTER" number.

If the numbers do NOT match, explain the reason in the "Notes" box to the right of certificate 3.

All poll workers present MUST print and sign their names on all 3 return sheets.

## Filling Out the Return Sheets: Certificate 2

All certificates are located on the large *Pink, Aqua and White Return Sheets* (see page 79). There are no individual certificates.

There are 3 Return Sheets included in your paperwork, they must all be filled out completely and identically.

Certificate 2 is a record of ballots cast and closing security measures. Use these instructions, along with the infographic on the opposite page, to fill out Certificate 2.

- The vDrive compartments are resealed after removing the vDrives as shown on page 77. Record the numbers from **Blue Security Seals** (from the blue bag) placed on the vDrive compartments inside the Scanner *and* the Touch Writer at closing.
- Record the number of ballots cast from the Ballot Counter number on the Scanner's Close Polls Report. In the example, 43 ballots were cast.
- Record the Lifetime Counter number from the Close Poll Reports for both the Scanner and the Touch Writer. In this example, the Scanner's lifetime count is 5732 and the Touch Writer's lifetime count is 83.
- Record the closing seal number from the **Red Security Seal** from the blue bag on the equipment cage. **Do not seal the cage until you are ready to leave the precinct.**
- Record the number from the **Blue Security Seal** (from the blue bag) placed on the printer port on the back of the Touch Writer at closing.
- Record the total number of voters who voted at the precinct. This will be the final line from the Numbered List of Voters in the binder, minus any crossed out and unused lines.
- In this example, the last number is 44 and there was 1 cross out. So, the actual number of voters who signed the blue poll book is 43.

**IMPORTANT NOTE:** The TOTAL # VOTERS number [see 5 on next page] should match the scanner's BALLOT COUNTER number [see 2 on next page]. If the numbers do not match, explain the reason for the difference in the discrepancy box to the right of Certificate 3. The reason must be explained on ALL 3 return sheets.



# Filling Out the Return Sheets: Certificate 2

POLL CLOSING - CERTIFICATE 2			
After closing the polls, record these numbers from the equipment, tapes, and numbered list of voters.			
ELECTION EQUIPMENT	BLUE Seal Number vDrive Compartment Seal when Repacking	BALLOT COUNTER from Machine Tape	Lifetime Counter from Machine Tape
Ballot Scanner	1 0005226	2 43	3 5732
TouchWriter	0005225		4 83
RED Seal # on Cage:	Used to seal cage	BLUE Seal # Back of TouchWriter:	At closing
<b>TOTAL # VOTERS: From numbered list of voters</b>	5 43	Record the last number displaying a voter from the numbered list, minus any lines that were crossed out and unused. (see pic 44-1=43)	



Seal numbers from blue security seals installed on both vDrive compartments after removal of the vDrives.

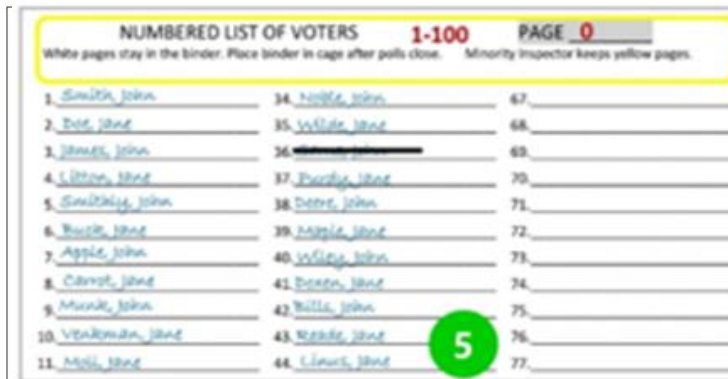

Election Header	
Poll Worker Training - General	
Election Date: 10/31/2021	
Delaware County, Pennsylvania	
Delco Elementary School	
Election Day	
Verity Scan	
S/N: S1903221810	
Version: 2.3.1	
Ballot Counter:	43
Lifetime Counter:	5732
Close Polls Report	

Election Header	
Poll Worker Training - General	
Election Date: 10/31/2021	
Delaware County, Pennsylvania	
Delco Elementary School	
Election Day	
Verity Touch Writer	
S/N: W1913547412	
Version: 2.3.4	
Ballot Counter:	6
Lifetime Counter:	83
Close Polls Report	

These tapes show a record of all votes cast.

Remember to sign the bottom of all machine tapes where indicated.

## Filling out the Return Sheets: Certificate 3

Certificate 3 is the paper ballot audit. It contains a record of all paper ballots delivered to and printed at the precinct. Use these instructions, along with the infographic on the opposite page, to fill out Certificate 3.

- Confirm the preprinted number agrees with the actual number of ballots received in the cage.
- Record the number of ballots printed in the precinct from the Touch Writer Close Polls Report.
- Record the total Provisional Ballots printed on the Touch Writer.
- Record the total number of unused ballots. Note: Unused ballots must be sealed in their box and placed back in the cage along with any empty cardboard boxes at the end of the night.
- Record the total number of spoiled ballots (from the Spoiled/Remitted Ballot Envelope). This count does **NOT** include any remitted absentee/mail-in ballots or Spoiled Touch Writer ballots.
- Record the **Green Seal Number** from the Black Pouch used to seal the gray ballot bag.
- Record the **White Seal Number** from the Black Pouch used to seal the **Green Tote**. Do not seal the **Green Tote** until all paperwork has been completed and filed.

**If there are any discrepancies, please explain it in the discrepancy box located next to Certificate 3 on the Return Sheet. The same reason must be noted on ALL 3 return sheets.**

Once all the certificates on all 3 Return Sheets are completed, **ALL** poll workers present at closing must print and sign their names at the bottom of the sheets.

- File the completed **Pink Return Sheet** in the **Pink Minority Inspector Envelope**.
- File the completed **Aqua Return Sheet** in the **Aqua Machine Warehouse Envelope**.
- Post the completed **White Return Sheet** with both the Write-In and Tally Report attached so it is visible from the outside of the precinct. Poll workers are not responsible for removing this posting.

# Filling Out the Return Sheets: Certificate 3

PAPER BALLOT AUDIT - CERTIFICATE 3	
Fill out at poll closing with all paper ballot numbers. Record seal numbers used for the live ballots.	
	BALLOTS
Total Ballots received in cage	Preprinted
Regular Ballots printed on Touch Writer	5-2 = 3
Total Provisional Ballots including Spoiled from the Provisional Voting Return Envelope	1 2
Total of Unused Ballots (Count remaining at poll close)	2 461
Total Spoiled Regular Ballots (Refer to spoiled/remitted ballot env.)	3 2
You must record these security seal numbers. Print numbers clearly.	
Scanner Gray Tote Bag Seal # Contains all scanned paper ballots	4 0003546
Green Tote Bag Seal # Contains all cast provisional votes	5 001171

Pct	Total
ALDAN BOR	
PRECINCT	5
EASTERN	
Total	5

Report includes a total of 2 provisional ballot(s)

Official Signatures  
*Joe Judge*

DELAWARE COUNTY BUREAU OF ELECTIONS  
SPOILED / REMITTED BALLOT ENVELOPE

- SPOILED BALLOTS:** If a voter overvotes or mismarks an Election Day Precinct Ballot, the voter may spoil that ballot to receive a replacement Precinct Ballot.
  - Mark the overvoted or mismarked ballot as spoiled.
  - Place the spoiled ballot in this envelope.
  - Make a log entry below.
- REMITTED MAIL BALLOTS:** If a voter decides to vote in person and turns in the Mail/ Absentee Ballot, they must surrender both the Mail/Absentee Ballot and the bar-coded Return Envelope that shows the voter's name to receive a replacement Precinct Ballot.
  - Place the Mail/Absentee Ballot and return envelope inside this envelope.
  - Complete and place electors declaration to returned Mail Ballot inside this envelope.
  - Do **NOT** make a log entry below.

Reason Spoiled: Overvote or Mismarked  
Spoiled By: Poll Worker Name

OVER VOTE RIPPED  
JOE JUDGE  
MAX MAJORITY

Delaware County  
November 5, 2024 General

PRECINCT:  
ALDAN Eastern

BOX #1  
Precinct Box: 1 of 1

TOTAL BALLOTS: 460 461 unused



# Security Seal Locations

Seal Color	Security Seal Location	Seal Placement at Poll Closing
White (1)	Black Pouch	Green Tote
Green (1)	Black Pouch	Gray Ballot Bag
Lime (1)	Poll Pad Case	Poll Pad
Blue (3)	Equipment Cage blue bag	vDrive compartments on scanner & Touch Writer and the Touch Writer's rear printer port
Red (1)	Equipment Cage blue bag	Equipment Cage

## Return Guide

**SUPPLIES MARKED "RETURN TO COUNTY" MUST BE INCLUDED AT THE END OF NIGHT DROP-OFF. IF YOU ARE MISSING ANY OF THESE ITEMS, YOU MUST RETURN TO THE PRECINCT TO RETRIEVE THEM FOR DELIVERY TO THE COUNTY.**

## Sealed Gray Scanner Ballot Bag with vDrive Envelope

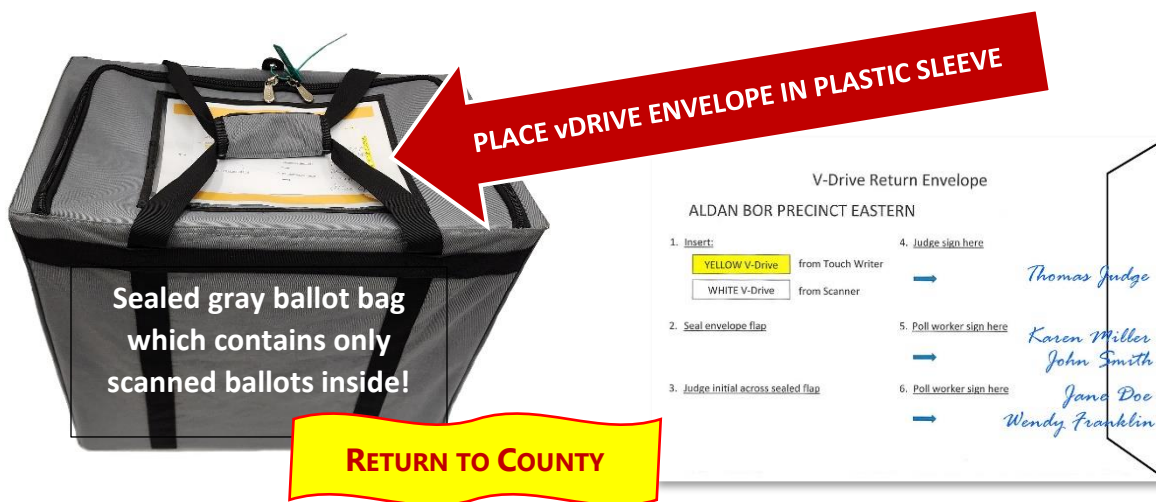

- Use the **Green Security Seal** located in the **Black Pouch** to secure the **gray ballot bag**.
- Record the **Green Seal Number** on all three (3) Return Sheets. (See Cert. 3 on page 82)

**The signed & sealed vDrive envelope will be placed in the clear sleeve on top of the sealed gray ballot bag.**

## Closing Inventory **IMPORTANT: Pack out what was packed in.**

### GREEN TOTE



#### GREEN TOTE CONTENTS:

- **Sealed baby-blue bag** containing the Blue Poll Books, Supplemental Poll Book Pages and Directions
- **Used Forms Envelope which contains:**
  - Used Yellow Affirmation of Elector Forms
  - Used Pink Declaration of Assistance Forms
  - Used White Record of Assisted Voters
  - Used Challenges of Elector's Affidavit
  - **ALL** Used and Unused Poll Book Entry Pages
- **Provisional Ballot supplies** – place all supplies into the large Ziploc bag, including:
  - Provisional Voting Return Envelope (page 86)
  - Unused provisional ballot envelopes, green secrecy envelopes & receipts
- **Unused Forms Envelope** (containing):
  - Blank Yellow Affirmation of Elector Forms
  - Blank Pink Declaration of Assistance Forms
- **Black Pouch with Codes**
- **Lemon Bureau of Elections Envelope** (page 86)
- **Pens and tape**
- **White Supply Box** (contents, see right)

### WHITE SUPPLY BOX

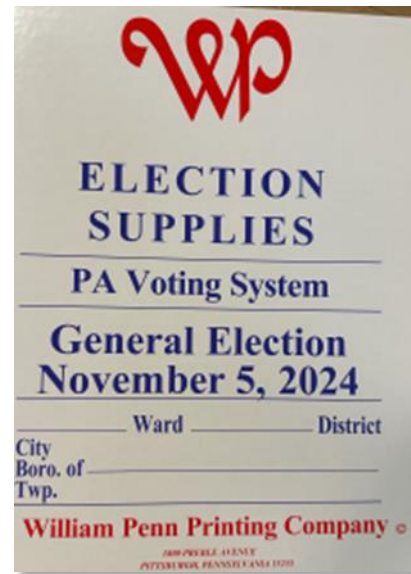

#### WHITE SUPPLY BOX CONTENTS:

- Blue Precinct Folder
- Unused Elector's Declaration to Return their Mail Ballot Forms
- Unused Challenges Elector's Affidavits
- Posting Notices
- Election Day Digest (may keep)
- Unused Statements of Complaint
- "I Voted" stickers
- Bag of Pens
- Sample Ballots
- Election Day Guide (may keep)

Once the **Green Tote** is completely packed, use the **White Security Seal** located in the **Black Pouch** to secure the **Green Tote**. Record the seal number on all Certificate 3 on all 3 Return Sheets (see page 83).

# PROVISIONAL VOTE – RETURN ENVELOPE

## REVISED Provisional Vote – Return Envelope and Instructions

1. Complete section #1.
2. **Both** the JOE and Minority Inspector must sign section #2.
3. The individual responsible for returning this packet to the County must complete section #3.
4. Place **ALL** provisional ballots including spoiled ones, provisional ballot stubs and a Touch Writer Ballot Count Report in the **White Envelope** and seal it.
5. **IMPORTANT:** Review all provisional ballots for JOE and Minority Inspector signatures before sending the envelope.

PROVISIONAL VOTING RETURN ENVELOPE

#1 MATERIALS TO INSERT IN THIS ENVELOPE  
Place all voted Provisional Ballot envelopes as well as all Spoiled ballots in this envelope

- Count of Voted Provisional Ballots in this envelope \_\_\_\_\_
- Count of Spoiled Provisional Ballots in this envelope \_\_\_\_\_
- Total Provisional Ballots printed (voted + spoiled) \_\_\_\_\_

Place all Touch Writer Provisional ballot stubs in this envelope  
Seal this envelope and store the Green tote for return to the Board of Elections  
Seal the Green tote using the security seal

Record the security seal number on all three(3) Return Sheets

#2 FOR THE JUDGE OF ELECTION  
1. Enclose all voted and spoiled Provisional Ballots plus the Touch Writer provisional ballot stubs inside this envelope  
2. Enclose Touch Writer Ballot Count Report  
3. Judge of Elections along with Minority Inspector, review the completed Provisional materials associated with voted and spoiled Provisional ballots enclosed in this envelope.  
I, hereby swear, in accordance with Pennsylvania Election Code, that the information provided in this section is accurate and complete.

Judge of Election Print Name \_\_\_\_\_ Minority Inspector Print Name \_\_\_\_\_  
Judge of Election Signature \_\_\_\_\_ Minority Inspector Signature \_\_\_\_\_

#3 PERSON WHO RETURNS ELECTION NIGHT SUPPLIES  
1. Individual who returns the Provisional Ballots to the Election Board must print and sign below

Print \_\_\_\_\_ Sign \_\_\_\_\_  
(Individual's Full Name)

PLACE PRECINCT LABEL HERE

**ADD TO TOTE**

# LEMON BOE ENVELOPE

## LEMON BOE ENVELOPE CONTENTS

1. **Lemon Pay Sheet** (MUST be signed & filled out by all workers to ensure payment)
2. Signed Election Officer's Oath Affidavit
3. Signed Affidavit of Voter ID
4. Used Statements of Complaint-Title III
5. Any important messages or Poll Pad tickets with notes

Lemon

BUREAU OF ELECTIONS  
ENVELOPE

City | Twp | Boro \_\_\_\_\_ Election Date \_\_\_\_\_  
Month \_\_\_\_\_ Date \_\_\_\_\_  
Dist \_\_\_\_\_ Precinct \_\_\_\_\_ Year \_\_\_\_\_

Signed Officer's Oath of Office—closing	Signed Affidavit of Voter ID—closing
Used Statements of Complaint—Title III	Pay Sheet—Must be signed and signed off by the workers on at the

Check Here  
If you have enclosed an important message that needs immediate review by The Bureau of Elections.

Judge of Election Signature \_\_\_\_\_ Minority Inspector Signature \_\_\_\_\_

**ADD TO TOTE**

# LIME POLL PAD ENVELOPE

## LIME POLL PAD ENVELOPE (IN FRONT OF NUMBERED LIST BINDER) CONTENTS

1. Poll Pad Tickets
2. Broken Lime security seal/s from Poll Pad/s
3. Seal and leave in Numbered List Binder

Lime

Poll Pad Tickets Envelope

PLACE PRECINCT LABEL HERE

Electon Date \_\_\_\_\_  
Month \_\_\_\_\_ Date \_\_\_\_\_  
Year \_\_\_\_\_

Poll Pad Tickets  
(Place all tickets inside this envelope)

OPENING Poll Pad Security Seal  
(Please sign the serial number of the seal and write it in the blank. Place the broken seal inside the envelope.)  
Serial # \_\_\_\_\_

CLOSING Poll Pad Security Seal  
(Please sign the serial number of the seal and write it in the blank. Place the seal security seal back in the same going back.)  
Serial # \_\_\_\_\_

Judge of Election Signature \_\_\_\_\_ Minority Inspector Signature \_\_\_\_\_

**NOTE:** Some larger precincts may have more than 1 envelope and some may be manila. The Numbered List binder will be placed on the top shelf of the equipment cage.

# Equipment Cage, Aqua Envelope and Pink Envelope

## EQUIPMENT CAGE



## AQUA MW ENVELOPE

### REPACK, SEAL AND COVER

- Repack the equipment per the packing assistance guide and Manifest Sheet
- Sealed & signed cardboard ballot boxes with unused ballots plus any empty boxes
- Poll Pad or Poll Pads
- Metal sign stand and all laminated signs
- Electric cord and power strip (if provided)

### PLACE THE FOLLOWING ON THE TOP SHELF:

- **NEW: Spoiled/Remitted Envelope**
- Numbered List of Voters White Binder containing **Lime POLL PAD Sealed Envelope**
- **Aqua Machine Warehouse Envelope**
- Completed Manifest Sheet

### AQUA MACHINE WAREHOUSE CONTENTS:

- Scanner & Touch Writer Zero Reports
- Scanner & Touch Writer Open Polls Reports
- Touch Writer Close Poll Report
- Scanner & Touch Writer Power on Self-Test Reports
- All broken **Security Seals** except the Lime Poll Pad seal
- Aqua Return Sheet w/Close Polls Report attached
- **NEW: Any unclaimed party Tally Reports**

## PINK MINORITY INSPECTOR ENVELOPE

### PINK MINORITY INSPECTOR CONTENTS:

- Scanner & Touch Writer Zero Reports
- 1 Signed Election Officer's Oath Affidavit
- Touch Writer Ballot Count Report
- Used **Yellow Numbered List of Voters** (from white binder)
- Pink Return Sheet w/ Tally Report attached

## Drop Off Rules and Information

- **IMPORTANT:** If a non-poll worker is returning the materials, they must have a signed affidavit (Call the Poll Worker Hotline at (484) 460-3750 for directions).
- **IMPORTANT:** The white vDrive Envelope will be placed in clear sleeve on top of the *gray ballot bag*.
- Poll Pads are returned in the cage.
- All precincts will return materials promptly on ELECTION NIGHT to the Government Center in Media.
- Only **ONE** person wearing the ID Badge on lanyard with the keys per precinct will be admitted in the building to return materials.
- Assistance carrying the materials will be available in the Third Street garage, if needed.
- Parking is also available on nearby streets for entry through the courtyard.



# Appendix A: Voter Intimidation and Electioneering

**No one may electioneer or attempt to influence voters inside the polling place or within 10 feet of the entrance of the voting room.**

The Judge of Election must instruct any violators to move outside or away from the door. The Judge of Election must preserve the rights of voters to cast their ballots in private and free of interference, and NOT allow:

<ul style="list-style-type: none"> <li>▪ Aggressive behavior inside or outside the polling place.</li> </ul>	<ul style="list-style-type: none"> <li>▪ Disseminating false or misleading election information.</li> </ul>
<ul style="list-style-type: none"> <li>▪ Blocking the entrance to the polling place.</li> </ul>	<ul style="list-style-type: none"> <li>▪ Vandalism of polling places.</li> </ul>
<ul style="list-style-type: none"> <li>▪ Election workers treating voters differently in any way based on race or other characteristics.</li> </ul>	<ul style="list-style-type: none"> <li>▪ Confronting voters, or demanding documentation or ID when none is required.</li> </ul>
<ul style="list-style-type: none"> <li>▪ Disrupting voting lines inside or outside of the polling place.</li> </ul>	<ul style="list-style-type: none"> <li>▪ Photographing or videotaping voters to intimidate them.</li> </ul>
<ul style="list-style-type: none"> <li>▪ Violence or using the threat of violence to interfere with a person’s right to vote.</li> </ul>	<ul style="list-style-type: none"> <li>▪ Poll watchers confronting, hovering over, or directly speaking to voters.</li> </ul>
<ul style="list-style-type: none"> <li>▪ Poll workers or poll watchers making repeated frivolous challenges to voters without a good faith basis.</li> </ul>	<ul style="list-style-type: none"> <li>▪ Using insulting, offensive, or threatening language, or making taunting chants inside the polling place.</li> </ul>

**The Judge of Election must ensure that no voter intimidation happens in or around the polling place.** Take all reports of voter intimidation seriously! Call the DA.

If you see or hear that someone is acting disruptively at or around the polling place, the Judge of Election or designated poll worker should immediately approach that individual to de-escalate the situation.

If de-escalation is not successful and the individual refuses to leave, contact the Constable. If a Constable is not available, contact law enforcement. However, this should be the last resort to prevent complaints of voter or poll watcher intimidation.

## Appendix B: De-Escalation Guidance

**GOAL** – Handle disruptions at the polling place in a fair, legal, and effective way regardless of the identity or political affiliation of the disruptor. De-escalation may not resolve an issue immediately. Responders should focus on slowing the conversation down and minimizing disruption of election operations.

- Planning ahead makes your job easier in the moment
- Projecting empathy, confidence, and genuine concern is key to effective de-escalation
- Identify staff members well-suited to this task and consider choosing a “designated responder”
- Do not make it personal – use phrases like “State law does not allow...” instead of “you are not allowed...”
- Familiarize yourself with State and Federal laws concerning polling place disruptions
- Offer the Statement of Complaint – Title III
- Know who to contact for help

### Steps for De-Escalating a Situation

**Stay calm** – Check in with yourself to make sure you appear calm and self-assured. Your affect and body language should express caring interest in their perspective – not impatience or skepticism. Do NOT cross your arms or put your hands on your hips.

**Listen** – Actively listen to the disruptor’s concerns and look for clues about feelings, needs, or values. Ask simple, open-ended questions (“Will you tell me what your concerns are?”). Try to name the emotion you believe is being expressed (“I’m hearing that you are frustrated” or “I sense your aggravation at this situation.”).

**Affirm** – Repeat what you understand their points to be (“I hear your concern for safety” or “I hear that your concern is ...”). Invite repeated cycles of response and clarification in an effort to slow the conversation and allow the disruptor to see that you are listening and attempting to understand. This is also a good time to gently move the disruptor away from other voters who might become agitated or feel intimidated.

**Respond** – Only after questions and listening have been exhausted should the poll worker begin to respond. Emphasize that you want to help. Remind them that you are committed to enforcing the rules that are in place to protect all qualified voters’ right to vote. You may invite the disruptor to review with you the postings inside the polling place that reference voting rights, instructions, and penalties. When informing disruptors of legal restrictions, emphasize that they are bound to the law but suggest that the disruptor can make their views known to their legislators.

**Assess** – If the above techniques are not working, STOP. Get help.

## Appendix C: Emergency Information

**In the event of any of the following emergencies, have the JOE call the Poll Worker Hotline at (484) 460-3750 as soon as possible.**

***In the event of a life-threatening situation, call 911 immediately.***

In the event of an evacuation, keep poll workers and voters out of the building. If time and conditions permit, prioritize taking the Numbered List of Voters and then Poll Pads, Provisional Ballots and voting equipment with you. Safeguard any items taken. All poll workers shall meet outside, and the JOE shall make sure everyone is accounted for. Poll workers can wait in vehicles outdoors if weather conditions warrant. Await further instructions as to relocation or other pertinent info.

**MEDICAL EMERGENCY (STAFF OR VOTER):** Call 911. After situation has been addressed, call the Poll Worker Hotline to report the incident and determine next steps.

**FIRE/GAS LEAKS:** Evacuate the building and call 911. If time and conditions permit, first take the #’d List of Voters and then the Poll Pads, Provisional Ballots and voting equipment with you. Safeguard items taken. All poll workers shall meet outside, and the JOE shall make sure all are accounted for.

**SEVERE WEATHER/TORNADO:** Seek shelter in the lowest level of the building, away from windows. If time and conditions permit, prioritize taking the Numbered List of Voters and then Poll Pads, Provisional Ballots and voting equipment with you and safeguard. The JOE shall make sure all are accounted for. Everyone who can get on their knees and elbows while protecting their head should.

**LOSS OF POWER:** Open blinds and curtains to allow as much natural light as possible. The voting equipment works on backup battery power for up to two hours. When AC power is not available, the Scanner and Touch Writer will automatically switch over to battery power, and a warning message will display. To dismiss the message and continue operating on battery power, touch **“If the power is out, touch here to use battery.”** If a voting session is in progress, this message will not appear until the session is completed. Call the Machine Warehouse to report the outage.

**SUSPICIOUS PACKAGE/BOMB THREAT:** Do not touch/move the suspicious item(s.) Call 911. If evacuation is required and time permits, prioritize taking the Numbered List of Voters and then the Poll Pads, Provisional Ballots and voting equipment with you. Safeguard any items taken. The JOE shall make sure everyone is accounted for. Await further guidance from law enforcement.

**WEAPONS SITUATION:** If a weapon is displayed in a hostile way, call 911. If evacuation is required and time permits, prioritize taking the Numbered List of Voters and then Poll Pads, Provisional Ballots and voting equipment with you. Safeguard any items taken. The JOE shall make sure everyone is accounted for.

### **WHEN TO CALL THE POLICE:**

Police, whether in uniform or not, may only be in a polling place when: responding to an emergency, keeping the peace, serving a warrant, or casting their own ballot. If there is a problem, contact a Constable if possible. **Call the police when:**

- A true emergency threatens bodily harm of a person in or near the polling place, or,
- Any person repeatedly disrupts the polling place and/or repeatedly ignores or refuses to follow the directions of the JOE, and the matter cannot be resolved by the JOE, the members of the local election board, or the Constable.

## Appendix D: Emergency Ballot Box Procedure

If the precinct scanner malfunctions or is not reading ballots properly, even after opening a different bundle of ballots, follow these procedures. This will allow voters to continue casting ballots until the scanner is repaired or replaced.

**DO NOT REBOOT THE SCANNER.  
DO NOT ATTEMPT TO TROUBLESHOOT THE SCANNER WITHOUT EXPLICIT  
APPROVAL OF THE VOTING MACHINE WAREHOUSE.**

1. Voters can continue to cast their ballots if there is a need to troubleshoot the scanner.
2. Instruct voters to place their ballots in the manual emergency slot located in front of the scanner on the right side of the ballot box.
  - Ballots will be collected in a separate bag within the ballot box.
3. Contact the Voting Machine Warehouse **(610) 874-8780** to resolve the scanner issue.
4. When the scanner is fully functioning, a bi-partisan team of poll workers will scan the ballots. This is the only time any of the poll workers will touch live ballots.
  - Remove all ballots from the emergency bag (use the blue ballot box key to open the rear door of the scanner).
  - Scan all ballots.
5. Complete the paperwork from the Machine Warehouse Personnel.



**IMPORTANT:** In case of an overvote or blank page, tap “Cast Ballot As-Is.”

**Ballot Drop Slot  
FOR EMERGENCY USE ONLY**



## Appendix E: Replacing Machine Report Paper

If the Scanner or Touch Writer runs out of paper while printing a report, simply replace the paper and reprint that report.

### Machine tape replacement

1. The thermal report printer is located on the right-hand side of the Verity Device ▶



2. To open the paper compartment: While standing in front of the device, pull the lever on the top of the printer cover towards you and lift up to open the paper compartment. ▶



3. To replace paper: Place the new paper roll into the printer as shown. Paper must roll up from the bottom. ▶



4. Close the printer cover. The paper must extend out from underneath the front edge of the cover. The white button can be used to advance the paper. ▶



## Appendix F: Voters with Specific Needs

- **Respect every voter.** Remember that the voter is a person first, the disability comes second.
- **Be considerate and patient.** Some voters may need more time to communicate or to accomplish a task.
- **Communicate with the voter.** Some voters with Specific Needs may have an assistant or a companion with them. Look at and speak directly to the voter, rather than the assistant.
- **Encourage accessibility.** Make sure the most accessible way to access your precinct is clearly marked. All poll workers should be familiar with accessible access points to the precinct.

### Working with voters who are blind or visually impaired:

- **Identify yourself as a poll worker.** Do this as soon as you are interacting with the voter. Offer your own arm, rather than taking the voter's arm, when assisting. Help the voter avoid obstacles in the path of travel by being specific when giving verbal directions.
- **If the voter has a service animal,** walk on the opposite side of the voter, away from the service animal. Do not pet or interact with the service animal without the owner's permission.
- **Describe what you are doing as you do it.** If walking away from a person who is blind or visually impaired, let them know.

### Working with voters with speech/hearing impairments:

- **Allow a voter who cannot speak** to write their name and address to provide identification.
- **Follow the voter's cues.** This will help determine whether speaking, gestures, or writing is the most effective means of communication.
- **If speaking, speak calmly, slowly, and directly to the voter.** Do not shout.
- **Rephrase rather than repeat sentences that the voter does not understand.**

### Working with voters with limited mobility:

- **Do not push or touch a voter's wheelchair without their consent.** People using adaptive equipment often consider the equipment as part of their personal space.
- **Ask before helping.** Grabbing a voter's elbow may throw a person off balance. A person with mobility impairments might lean on a door while opening it. Quickly opening the door may cause a person to fall.
- **Secure mats, rugs and cords to the floor** or move them out of the way. This will help prevent tripping.
- **Keep ramps and wheelchair accessible doors unlocked and free of clutter.**

## Appendix G: Poll Pad Issues

### Not Printing/Stops Printing

1. Make sure the printer is turned ON. (Blue light will be on). [A]
2. Confirm the printer is plugged into outlet and cords are securely connected.
3. Check paper is properly installed and that roll is not feeding from the bottom. (See below.)
4. Confirm connections with Poll Pad (green icon). [B]

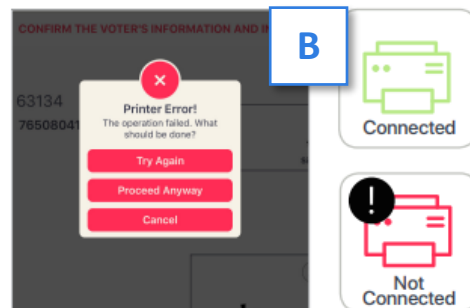

### Changing Paper

1. Open the front of the printer by pulling the lever down as shown in the photo. [C]
2. Reload the paper with the paper flap toward you, feeding from the top of the roll.
3. Close and press **Print Test Receipt**. File in the Lime Poll Pad Envelope.

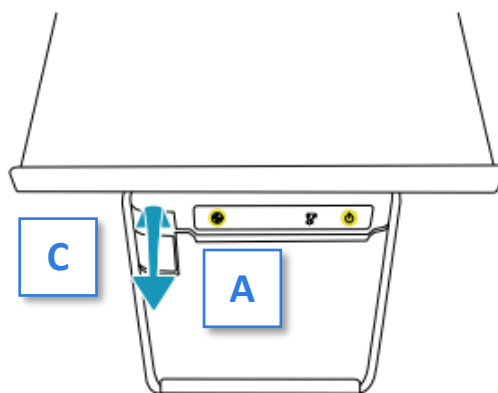

### Charging Poll Pad

If the iPad power is very low or zero, use the power cube – each polling place will have one.

1. Plug the USB end of power cable into the power cube.
2. Plug the power cube directly into a wall outlet.
3. Plug the power cable into the iPad.
4. Wait about 5 minutes to charge the iPad enough to automatically power on.
5. Resume normal operations.

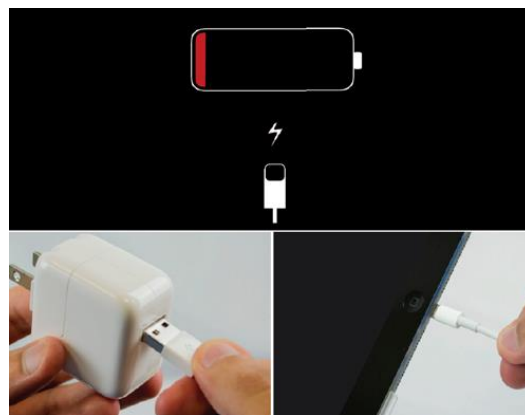

To confirm the iPad is charging, the battery icon should be green with a lightning bolt.

### Cleaning the iPad and Stylus

- Use the cloth provided in the case for the iPad and styluses.
- Do NOT use liquids or wipes on the iPad!
- You may use a disinfect wipe on the stylus **but be careful to not wipe the stylus's soft rubber tip.**

# Appendix H: Poll Worker Positions

## Judge of Elections, aka the JOE

- Oversees all Election Day activities and personnel inside the polling place, including the Constable
- Serves as the primary contact for poll workers assigned to work for their precinct
- Communicates with the polling place prior to Election Day to ensure access to the building
- Picks up the JOE kit in advance of Election Day
- Determines set-up of polling place to serve voters efficiently while maintaining voter privacy
- Opens the supply cage and assigns tasks to ensure the timely opening and closing of polls
- Maintains order at the polling site by enforcing regulations
- Ensures thorough completion of all Election Day paperwork
- Responsible for returning election supplies to Media after the polls have closed

## Majority Inspector

- Assists the JOE with the opening and closing of the polls
- Performs duties as assigned by the JOE which may include check-in of voters, maintaining hand-written record of voter names, handing out ballots and assisting the Machine Operator
- Checks voters in on a poll pad and directs them to the next station
- Assists the JOE with end-of-night paperwork
- Performs other duties as assigned by the JOE

## Minority Inspector

- Same responsibilities as Majority Inspector (see above)
- May appoint a Minority Clerk to assist on Election Day
- Countersigns much of the paperwork including the Provisional Ballot Envelopes
- Takes home the sealed Minority Inspector Envelope on election night and keeps it for two years

## Clerk

- Assists the JOE with the opening and closing of the polls
- Performs duties as assigned by the JOE which may include check-in of voters, maintaining hand-written record of voter names, handing out ballots and assisting the Machine Operator

## Machine Operator

- Assists the JOE with the opening and closing of the polls
- Oversees the operations of the ballot scanning equipment and marking device on Election Day
- Assists voters at the ballot scanner while maintaining voter privacy
- Performs other duties as assigned by the JOE



# Appendix I: Machine Reports

A detailed explanation of the information contained on reports and how to read them.

Understanding Machine Tapes

Election Header

2021 MUNICIPAL PRIMARY  
Election Date: 5/18/2021

COUNTY OF DELAWARE  
TRAINER Upper  
Election Day Voting

Verity Scan  
S/N: S1903170710  
Version: 2.3.1

Ballot Counter: 0  
Lifetime Counter: 2

Zero Report

Date & Time Printed:  
03/04/2021 1:23 PM

Tally Report By Precinct

Qty Pcts/Splits Included: 1

**Democratic Party**

TRAINER Upper  
JUSTICE OF THE  
SUPREME COURT

**Republican Party**

TRAINER Upper  
JUSTICE OF THE

**Nonpartisan Party**

TRAINER Upper

Question #1

Yes 0  
No 0  
Undervotes 0  
Overvotes 0

Precinct Ballot Count

Precinct	Total
TRAINER Upper	0
<b>Total</b>	<b>0</b>

All ZEROS

Official Signatures

Election Header

2021 MUNICIPAL PRIMARY  
Election Date: 5/18/2021

COUNTY OF DELAWARE  
TRAINER Upper  
Election Day Voting

Verity Touch Writer  
S/N: W2013619401  
Version: 2.3.4

Ballot Counter: 6  
Lifetime Counter: 9

Close Polls Report

Date & Time Printed:  
03/04/2021 3:02 PM

Polls are Closed

Ballot Count Precinct Report

Qty Pcts/Splits Included: 1

Democratic Party  
Republican Party  
Nonpartisan Party

Pcts/Splits Voted Total: 1  
Total Ballots Printed: 6

Democratic Party	Total
Pct	
TRAINER Upper	3
<b>Total</b>	<b>3</b>
<b>Republican Party</b>	
Pct	
TRAINER Upper	2
<b>Total</b>	<b>2</b>
<b>Nonpartisan Party</b>	
Pct	
TRAINER Upper	1
<b>Total</b>	<b>1</b>

Official Signatures

**Election Header (circled in BLUE)**  
Election Details - Type of Election & Date  
Precinct Identifier - Your Precinct Name/ID  
Device Identifier - Scanner or TouchWriter  
Device Serial No. - Unique S/N

Ballot Counter & Lifetime Counter are also displayed here for easy recording onto the return sheet.

**Type of Report (circled in RED)**  
Power-On Self Test, Zero, Open Polls, Close Polls, Tally, Write-In & Ballot Count.  
Check this area on tape if you are looking for a particular tape

**Data Contained in Reports**

Full machine tapes will be very long (primary tapes can be 6 ft or longer)

Primary races will be itemized by party and will include Democratic, Republican and Nonpartisan (now listed as Third Party) sections showing all races and questions.

Closing Tapes will show final ballot counts and partisan breakdown of ballots cast at the bottom of the tape near the signature area.

This information is displayed here for easy recording onto the return sheet.

**Official Signature Area (circled in PURPLE)**  
Found on bottom of most machine tapes.  
**Do not forget to sign** the tape where indicated and properly file the tapes as indicated in the opening/closing instructions.



**Thank you for the long hours and the dedication  
you put into ensuring a fair election.**

**Your service is invaluable to our community and  
democracy.**

**We look forward to working with you again.**

# Election Day – Poll OPENING Checklist

## Equipment Verification – Call Warehouse if issues.

- Verify Equipment Cage is for YOUR precinct.
- Record the removed **RED SECURITY SEAL #** on all 3 return sheets and place in **AQUA MACHINE WAREHOUSE ENV.**
- Record **BLUE SECURITY SEALS #** from scanner & Touch Writer's vDrive compartments on return sheets.  
**DO NOT REMOVE SEALS.**
- Record the removed **BLUE SECURITY SEAL #** from Touch Writer printer port on all 3 return sheets and place in **AQUA MW ENVELOPE.**

## Equipment Setup – Call Warehouse if issues

- Find open/close poll codes and keys in **BLACK Pouch.**
- Set up TW printer table, place printer on table and plug in.
- Set up TW stand, lock TW into place, open case, remove cords, set up tablet, plug in and connect to printer.
- Turn on printer. Press TW's **Red Power Button** to boot up. Power-on/Self-test report will print.
- Print 2 Zero Reports and verify zero ballots, precinct, date and time.
- Enter poll opening code. Poll Opening report will print automatically.
- Set up ballot box and assemble gray ballot bag.
- Position & lock scanner on top of ballot box, open case, remove cords & plug in.
- Press scanner's **Red Power Button** to boot up. Power-on/Self-test report will print.
- Print 2 "Zero Reports" and verify zero ballots, precinct, date and time.
- Enter poll opening code. Poll Opening report will print automatically.
- Attach privacy screens to sides of each device and position for maximum voter privacy.
- Set up voting booths and plastic privacy screens.
- Set up the Poll Pad/s.

## Judge of Election Table Setup

- Ready all provisional voting materials, blank poll book pages, remitted ballot materials, colored envelopes, return sheets, etc.

## Check-In & Precinct Table Setup

- In shared locations, set up the central Poll Pad check-in table with Poll Pads and Affirmation and ATV forms.
- In shared locations, use display signs to guide voters to correct precinct after check-in.
- Set up the precinct table with ballots, pens, Poll Pads (in single precincts), privacy folders, White binder and Spoiled/Remitted Ballot Envelope.

## Paperwork

- Sign both Oath of Office forms: File them in the **LEMON BOE ENVELOPE** and **PINK MINORITY INSPECTOR ENVELOPES.**
- Complete and sign Pay Sheet: File in **LEMON BOE ENVELOPE.**
- Verify that ballots match precinct and count is correct and record on all 3 return sheets. Open 1 pack at a time.
- File blue and red removed seals in **AQUA MW ENVELOPE.**
- 3 Return sheets - fill out Certificate 1 at poll opening, using data from machine reports and security seals.
- Complete Manifest Sheet from Equipment Cage.
- File Machine Reports, as indicated below.
- Hang posting notices and sample ballots.

## Poll Opening Machine Reports and Storing Them

- SIGN ALL MACHINE REPORTS BEFORE STORING except the Power-on reports!**

### Touch Writer Reports

- 1 Power-On Self-Test: File report in AQUA MW Env**
- 2 Signed Zero Reports: File 1 each in **AQUA MW & PINK MINORITY INSPECTOR ENVELOPES.**

- 1 Signed Open Polls Report: File in **AQUA MW ENVELOPE.**

### Scanner Reports

- 1 Power-On Self-Test: File report in AQUA MW Env**
- 2 Signed Zero Reports: File 1 each in **AQUA MW and PINK MINORITY INSPECTOR ENVELOPES.**

- 1 Signed Open Polls Report: File in **AQUA MW ENVELOPE.**

# Election Day – Poll CLOSING Checklist

## Scanner Closing & Report Printing Procedure

- Check emergency ballot bag before closing polls. Scan any ballots found as-is before closing.
- Remove the gray ballot bag and seal with Green Security Seal and record on all 3 Return sheets.
- Press **BLUE BUTTON** on the back of scanner.
- Select **Close Polls** on the screen.
- Select **Yes, close the polls**.
- Enter the close polls code and select **Accept**.
- Close Polls report will print automatically. Sign the report and tape to the **AQUA RETURN SHEET**.
- 4 Tally Reports will automatically print. Sign all copies.
- Print 1 copy of the Write-In Report and sign.
- Press the **Red Power Button** to power off.
- Remove vDrive, place in **WHITE vDRIVE ENVELOPE**.
- Seal vDrive compartment using **BLUE SEAL** found in blue pouch and record the new **BLUE SEAL #** on the 3 return sheets.
- Pack scanner and ballot box in cage.

## Touch Writer Closing & Report Printing Procedure

- Press **BLUE BUTTON** on the back of Touch Writer.
- Select **Menu** on the upper-right corner of screen.
- Select **Close Polls** on the screen.
- Select **Yes, close the polls** on the screen.
- Enter the polls close code and select **Accept**.
- Close Polls report will print automatically. Sign the report and file in the **AQUA MW ENVELOPE**.
- Print 2 **Ballot Count reports** – file 1 each in **PINK MNI and WHITE PROV BALLOT ENVS**.
- Record # of ballots printed minus provisional ballots on all 3 Return Sheets.
- Press the **Red Power Button** to power off.
- Remove vDrive and placed in **WHITE vDRIVE ENVELOPE**. Seal and sign.
- Place White vDrive Security Env in top clear sleeve of the gray Ballot Bag.**
- Seal vDrive compartment and printer port using **BLUE SEALS** found in blue pouch & record the new **BLUE SEAL #** on the 3 return sheets. Pack Touch Writer, printer, and table in cage.

## Closing Accounting and Paperwork

- Count all unused ballots.
  - Record unused ballot count on all 3 return sheets.
  - Pack unused ballots and any empty boxes in cage.
- Separate Numbered Lists of Voters.
  - Remove used **YELLOW** pages and file in **PINK MINORITY INSPECTOR ENVELOPE**.
  - Place **WHITE NUMBERED LIST BINDER** in cage between printer and scanner.
- Place Provisional Ballots in the Provisional Ballot - Return Envelope and complete the Envelope
  - Verify all provisional ballots are signed by JOE and Minority Inspector.
  - Place all Provisional ballots and materials in large Ziploc bag and place in the **GREEN TOTE**.
- Complete all 3 return sheets and file as indicated:
  - Attach signed Close Polls report to **AQUA RETURN SHEET** and file in **AQUA MW ENVELOPE**
  - Attach signed Tally report to **PINK RETURN SHEET** and file in **PINK MI ENVELOPE**.
  - Attach signed Tally and Write-in reports to **WHITE RETURN SHEET** and post at precinct to be visible from outside.
- Confirm Pay Sheet is completely filled out, the JOE signed at bottom, then place in **LEMON BOE ENVELOPE**.
- Complete Affidavit for Voter ID & file in **LEMON BOE ENV**.
- Verify all 3 envelopes are properly filled, signed and placed in their final destination.
- Confirm items for return and ensure all remaining equipment is sealed in cage with the **RED SECURITY SEAL**.
  - Record seal number on all 3 return sheets.
- Pack & seal **GREEN TOTE** with **WHITE SEAL**.
  - Record seal number on all 3 return sheets.
- Pack up and seal Poll Pad and pack in cage.

## Return to County

- GREEN TOTE** sealed w/ **WHITE SECURITY SEAL**.
- Gray Ballot Bag sealed with **GREEN SECURITY SEAL** w/ vDrives in **WHITE vDRIVE ENVELOPE** placed in the **top clear sleeve**.